

m lit r

PRODUCT CATALOG

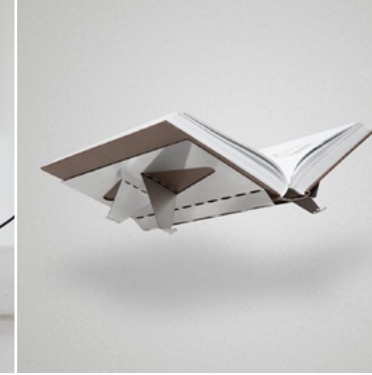

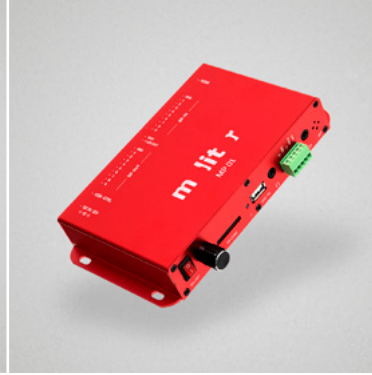

PRODUCT OVERVIEW

MOLITOR

ABOUT MOLITOR

- Motivation
- Location and workshops
- Sustainability
- Inclusion
- Our clientele

MEDIA TECHNOLOGY

HANDSETS

- VIA handset
- USO handset
- PLUX handset
- Handset accessory

HEADPHONES

- DIO headphones
- MIO single-ear headset
- Headphones accessory

LOUDSPEAKERS

- Directional speakers
- Cylindrical speakers
- For invisible installation
- Surface-mount speakers
- Satellite speakers
- Soundbars
- Cube speaker

- Music transmitter
- Active speaker set
- Outdoor speaker
- Spherical speaker
- Wall mount speaker

MEDIA PLAYER

- AP 01 audio player
- MP 01 media player
- MP 02 4K media player
- 4K Light media player
- Movebox media player
- Media player accessory

MEDIA STATIONS

- AIO All-in-One audio station
- MUSE multimedia cocoon chair

MONITORS

- Round video screen

MUSEUM PRODUCTS

GUIDANCE SYSTEM

- LEANDER guidance system

DISPLAY EQUIPMENT

- Mounting system
- Book cradle
- Sheet Display Board
- Spider Mount

DISPLAY SYSTEMS

- Columns
- Information boards
- Periaktoi

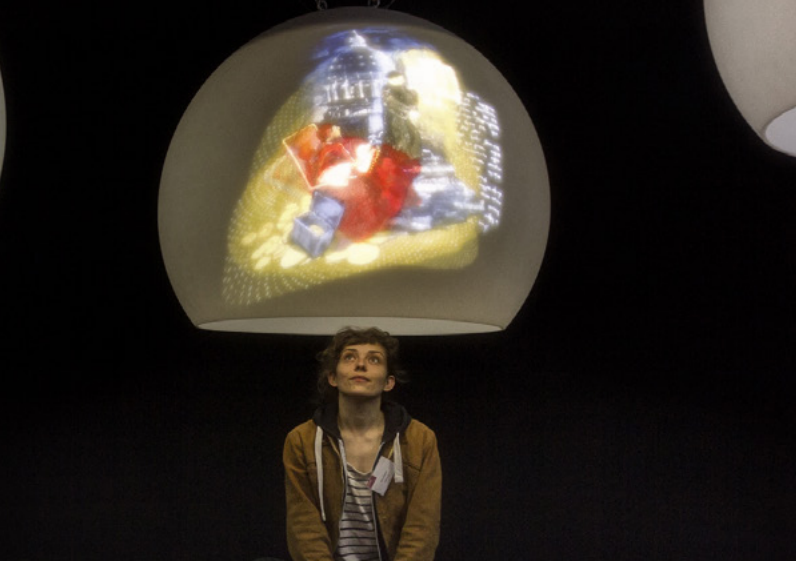
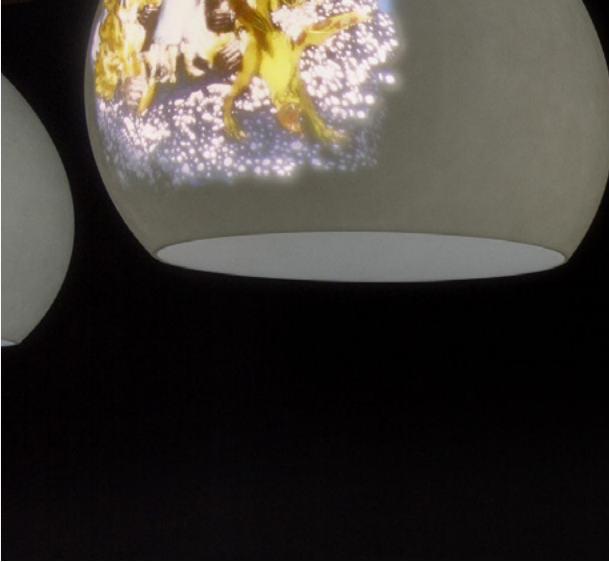

MOTIVATION

molitor curates, designs, and implements exhibitions and projects for art, culture, and science, and develops innovative products in the field of exhibition technology.

We feel no need to present a recognizable “brand style” of our own, but are instead solely committed to the project we are working on. To this end, we put together handpicked teams who are best able to meet the particular needs of each client. For project development, we make use of an extensive network of contacts and diverse specialist expertise in the fields of technology, planning, and design.

At molitor, we cover the entire spectrum from production and craftsmanship to design and feasibility studies, so we are equally familiar with the world of science, with the language of the creative, and with manual construction.

This means we can function as an intermediary between our clients and the tradespeople and contractors. We take what starts out as a mere abstract idea, and transform it into an experience for the senses, with playful interactive elements, exciting media exhibits, and matching scenic design.

We have our own research department, where we continuously work to develop new exhibition technology and products. In doing so, our focus is always on appealing visuals, intuitive handling, reliable equipment, and the most sustainable production possible.

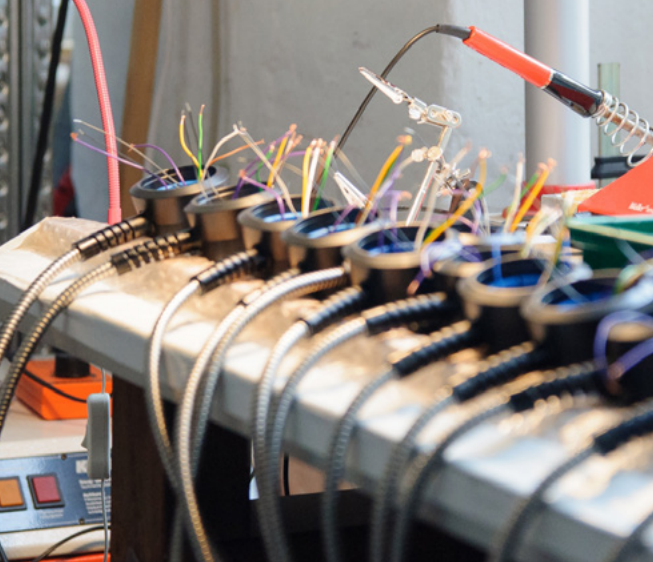

LOCATION AND WORKSHOPS

In our workshops, we produce the USO, VIA, and PLUX handsets, assemble audio and media players, and develop and build exhibits.

With years of experience in the production of exhibitions and exhibition technology, we have developed a range of products specifically designed for the particular requirements of the exhibition and trade show sector. We manufacture these in low-volume production runs. For special applications, we also create customized solutions in close cooperation with our customers.

In Berlin's Kreuzberg district, our offices are located under one roof together with the company's own workshops. Here we carry out assembly and final inspection of our AP 01 and MP 01 media players, the MP 02 4K player, and all our handsets. Unlike high-volume mass production, all models of our VIA, PLUX, and USO series are made by hand with great care. This means that each individual unit represents innovative robust technology and precise craftsmanship in equal measure. As most of

our suppliers are also located in Berlin, we can implement custom variants of our products quickly and easily.

In our media technology workshop, the controls, media equipment, and mechanical components of exhibits are brought together and produced in coordination with the client as a single piece or in a low-volume batch. We handle all phases from initial design and planning to prototype construction, production, assembly, programming, commissioning, and maintenance. For special requests, we can also draw on our large network of specialists.

We manufacture pedestals, display cases, and small exhibits in our wood workshop. We also make furniture and housings for exhibits. In our wood workshop, we also create sculptural objects from all kinds of materials such as plaster, cast resin, and polystyrene.

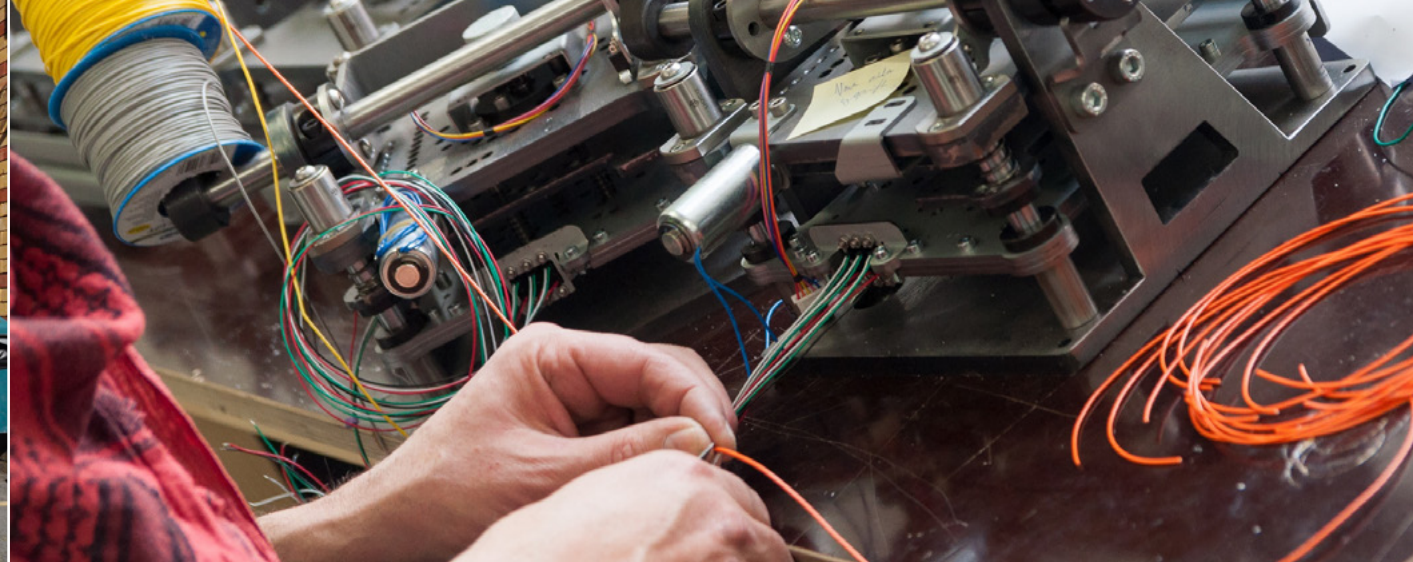

SUSTAINABILITY

As a broad-based, medium-sized company, we see it as our duty to act sustainably in all phases of our business, from project design to product manufacture.

We manufacture products which are robust and therefore long-lasting, and which can be operated with as little wear as possible. If at any time they cease to meet expectations or become damaged by vandalism, they can usually be repaired in our workshop. We keep the necessary spare parts in stock for many years.

We obtain the semi-finished parts for about 85 percent of the products we make from suppliers in Berlin and the surrounding region of Brandenburg. We strive to develop local, trust-based partnerships with small and medium-sized enterprises in our region. This reduces transportation, and the short

distances between us facilitate communication and quality control.

We use materials and energy as efficiently as possible, and our manufacturing processes are optimized accordingly. It is important to us to make maximum use of materials and to manufacture products in a way that produces little scrap or waste.

Our offices in Kreuzberg, Berlin, are very well connected to the public transit network. Less than 5 percent of our employees travel by car. This saves energy and reduces both emissions and land consumption for parking spaces.

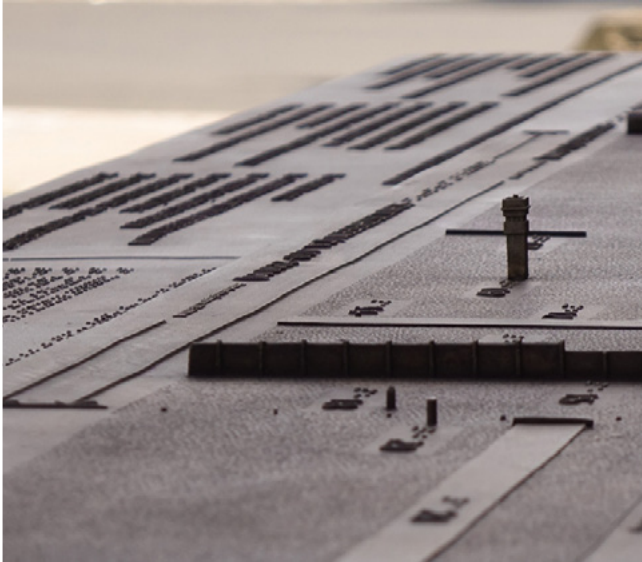

INCLUSION

Inclusion and accessibility are very important to molitor, and we seek to ensure that all visitors have equal access to the various contents of the exhibitions.

We rely on a language of communication aimed at several senses at the same time, and which thus involves both hemispheres of the brain. This enables long-term retention of information. It also satisfies the requirements of different learning types: Some people are more receptive to visual stimuli, others to auditory impressions. Many of our exhibits promote discovery with all the senses.

Thanks to the extensive use of auditory and tactile stations, even people with impaired vision can experience the content optimally. To prevent loss of contact with your own environment, which is very important for people with visual impairments, we designed the MIO single-ear headset. Our inductive handset,

on the other hand, is specially designed for people with hearing aids. The audio signal is transmitted directly to the telecoil, for high transmission quality. Moreover, our exhibits are printed in Braille and relief and, if possible, supplemented by tactile models from our partner Tactile Studio.

In our projects, we work to ensure normal lettering is easily legible, by eliminating glare and using suitable font sizes and high contrast. Switches and display panels are placed at a suitable height. When designing interactive exhibits, we are mindful of wheelchair accessibility. We also check whether folding wheelchairs, walking aids, and strollers can be made available to visitors.

OUR CLIENTELE

molitor – Global player from Kreuzberg in Berlin

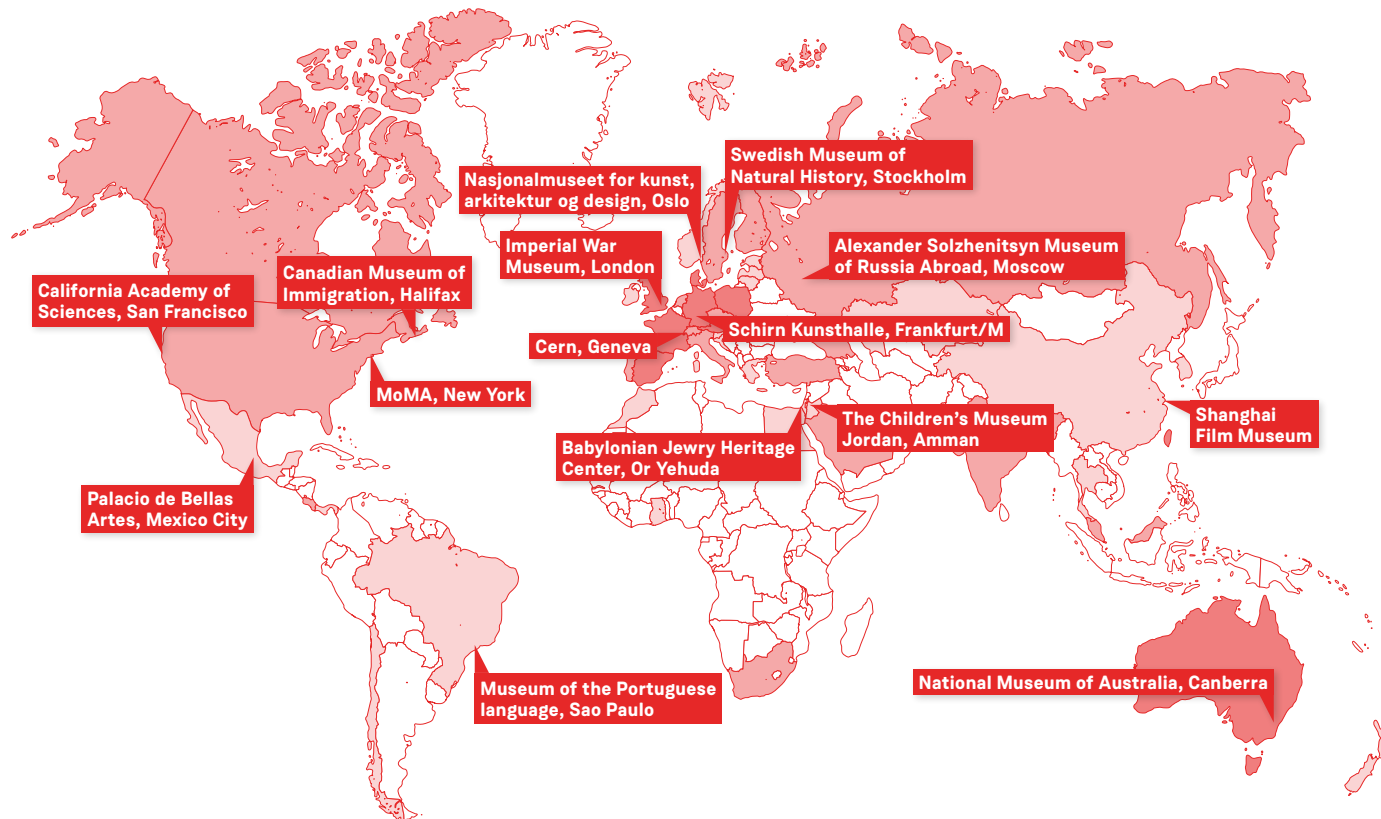

Exportländer von molitor Produkten und exemplarische Referenzen weltweit

Customers around the globe already rely on the quality of our media technology products. They are carefully assembled by hand in our workshops in Berlin's Kreuzberg district. The USO and VIA handsets, for example, have long since become classics, and are used in renowned museums throughout the entire world. Our products are becoming more widely used beyond the museum sector as well. So you may well have already had the pleasure of using one of our handsets yourself.

Our handsets are popular because of their highly effective technology and ease of use, as well as the large range of materials and colors to choose from. That range means we can provide models to suit any environment and any exhibition. We implement special requests and custom designs in close consultation with our customers.

Since we also offer all other necessary products such as media players, in addition to our wide range of handsets and headphones, we can give you a complete technically coordinated system, from a single source.

Our products can be purchased directly from our store and through numerous specialist dealers worldwide. If you would like to become a dealer for our products, please contact us.



HANDSETS

FULL SOUND QUALITY WITHOUT ISOLATION

Sound plays a major role in museums, exhibitions, and informational installations in buildings. Such applications require high sound quality, functional design, robust construction, and simple operation.

The handsets we have developed contain high-grade technical components that impress with their high sound quality and distortion-free reproduction of sound and speech. For easy operation, all the handsets are held on their base by a magnet. This ensures that no great

care is needed to return the handset to its exact position. The built-in reed contact automatically starts playing the audio when the handset is picked up, and stops playing it when the handset is replaced.

Thanks to the sleek design and a wide choice of colors and materials, all handset models fit perfectly into any room decor and interior design. The handset is compact, robust, hygienic, and intuitive in use, with equal appeal to all age groups.



VIA



THE HIGH-QUALITY CLASSIC

The VIA handset comes in many different models. In addition to a wide range of housing materials and different surfaces, there are versions for every conceivable installation situation: for wall mounting or as a tabletop unit; for indoor use and also an outdoor version.

The handset's unobtrusive styling allows it to blend perfectly into any surroundings. With its slim and conical shape, it fits comfortably and securely in the hand. The standard housing is injection-molded polyamide reinforced with glass fibers. This can be made in almost any

RAL Classic color. Housings made of aluminum can either be used untreated or can be refined with an anodized finish. A particularly robust alternative for outdoor use is a housing made of soft plastic. The back of the housing can be labeled by means of stickers or engraving, regardless of the material.

The VIA is held on its base by a strong magnet. When taken off its base, the audio starts playing automatically by activation of the reed contact. When replaced on the base, the playback stops. Optionally, the handsets can be equipped with a toggle switch for choosing between two languages or different audio tracks. An induction loop for direct transmission of the audio signal into induction-compatible hearing aids can be installed in all models with plastic housings.

A robust, flexible, stainless steel tube protects the connection cable and reliably secures the handset. All housings can normally be cleaned easily with a damp cloth or disinfectant. For special hygiene requirements, we provide handsets in antibacterial polyamide and in aluminum with an antiviral coating.

HANDSET

VIA Standard Polyamide

This VIA handset is made from glass-fiber reinforced polyamide as standard. The housing is exceptionally robust, fits comfortably and securely in the hand thanks to its conical shape, and can be cleaned easily.

The VIA is held on its base by a strong magnet. When taken off its base, the audio starts playing automatically by activation of the reed contact. When replaced on the base, the playback stops. Optionally integrated pushbuttons or rocker switches in the housing cover can be used for functions like selecting between two languages or navigating through menus. Engravings or stickers on the housing cover can be used to label these options. An induction loop for direct transmission of the audio signal into induction-compatible hearing aids can also be installed.

We manufacture the handsets in the colors Black, Basalt grey, Telegrey, and White. Virtually all RAL Classic colors are available as custom options.

A robust, flexible, stainless steel tube protects the connection cable and reliably secures the handset. A protective tube with plastic sheathing can be fitted as an option.

Flexible metal tube: length: 125 cm, dia.: 8 mm | **Connection cable:** length: 240 cm | **Weight:** (without base and protective tube) 170 g | **Speaker:** impedance: 32 Ω , max. power capacity: 0.1 W | **Sensor:** power rating: 10 W, voltage rating: max. 175 V (AC/DC), current rating: 0.5 A | **Colors:** Black, Basalt grey, Telegrey, White, custom RAL colors | **Optional:** pushbuttons, language selection switch, engraving, labeling, protective tube | **Accessories:** wall bushing



HANDSET

VIA Aluminum

The housing of this VIA handset is made from latheturned aluminum. It is exceptionally robust, fits comfortably and securely in the hand thanks to its conical shape, and can be cleaned easily.

The VIA is held on its base by a strong magnet. When taken off its base, the audio starts playing automatically by activation of the reed contact. When replaced on the base, the playback stops. Optionally integrated pushbuttons or rocker switches in the housing cover can be used for functions like selecting between two languages or navigating through menus. Engravings or stickers on the housing cover can be used to label these options.

The matt sheen of the aluminum is very appealing visually. In addition, the surface can be further refined by anodizing it in numerous colors or endowing it with the look of bronze or stainless steel.

A robust, flexible, stainless steel tube protects the connection cable and reliably secures the handset. A protective tube with plastic sheathing can be fitted as an option.

Flexible metal tube: length: 125 cm, dia.: 8 mm | **Connection cable:** length: 240 cm | **Weight:** (without base and protective tube) 170 g | **Speaker:** impedance: 32 Ω , max. power capacity: 0.1 W | **Sensor:** power rating: 10 W, voltage rating: max. 175 V (AC/DC), current rating: 0.5 A | **Colors:** natural aluminum, anodized aluminum in 20 colors | **Optional:** pushbuttons, language selection switch, engraving, labeling, protective tube | **Accessories:** wall bushing



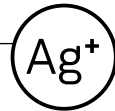

HANDSET VIA Antibacterial Polyamide

The antibacterial VIA handset is made from glass-fiber reinforced polyamide. The housing is exceptionally robust, fits comfortably and securely in the hand thanks to its conical shape, and can be cleaned easily. Moreover, silver ions embedded in the polyamide prevent the survival of bacteria on the housing of the VIA. We manufacture the handsets in Pigeon blue as the standard color. Virtually all RAL Classic colors are available as custom options.

All VIA models: **Flexible metal tube:** length: 125 cm, dia.: 8 mm | **Connection cable:** length: 240 cm | **Weight:** (without tabletop holder or protective tube) 170 g | **Speaker:** impedance: 32 Ω, max. power capacity: 0.1 W | **Sensor:** power rating: 10 W, voltage rating: max. 175 V (AC/DC), current rating: 0.5 A | **Optional:** pushbuttons, language selection switch, engraving, labeling, protective tube | **Accessories:** wall bushing

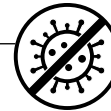

HANDSET VIA Antiviral Aluminum

The surface of the handset has an antimicrobial coating: Rhenoguard® AS. It kills microorganisms such as bacteria, viruses, and fungal cultures continuously and reliably, which reduces the colonization and transmission of germs. This effective, long-term protection from pathogens is even more important in times of heightened risk of infection, such as during the COVID-19 pandemic.



HANDSET VIA Soft Plastic (TPE) / version for outdoor use

The housing of the VIA is made of an exceptionally robust and non-slip soft plastic (TPE). It fits comfortably and securely in the hand thanks to its conical shape. For use outdoors, the device is specially sealed so that it is watertight. The standard color is black, but virtually all RAL Classic colors are available as custom options.

HANDSET

VIA Custom Materials

The housing of the VIA handset can be manufactured in a variety of attractive materials. The handsets differ in weight, robustness, and their processing options, depending on the material selected. Metal coatings such as copper plating are very high-quality, design-conscious finishes. Housings made of wood create a warm ambiance that brings nature to mind. We will be happy to advise you on how to turn your own ideas into reality.



HANDSET

VIA Induction

With inductive hearing systems, we can make audio tracks optimally accessible to hearing-impaired people. This is done by equipping the VIA handsets with induction hearing loops. The accompanying loop amplifier converts sound signals into electrical current, which is then emitted as an alternating electromagnetic field. A corresponding receiver coil—built into most hearing aids and cochlear implants—receives this signal and reproduces it with little disruption. The signal is thereby received without background noise, ensuring top-quality audio reception.

All VIA handsets with non-metallic housings can be fitted with induction loops. We supply them preassembled and ready to install, in a set together with loop amplifiers from our partner Audioropa. We also carry out planning, measurement, and installation of loop systems for entire rooms.

The VIA is held on its base by a strong magnet. When taken off its base, the audio starts playing automatically by activation of the reed contact. When replaced on the base, the playback stops. Optionally integrated pushbuttons or rocker switches in the housing cover can be used for functions like selecting between two languages or navigating through menus. Engravings or stickers on the housing cover can be used to label these options.

A robust, flexible, stainless steel tube protects the connection cable and reliably secures the handset. A protective tube with plastic sheathing can be fitted as an option.

Flexible metal tube: length: 125 cm, dia.: 8 mm | **Connection cable:** length: 240 cm | **Weight:** (without base or protective tube) 170 g | **Speaker:** impedance: 32 Ω, max. power capacity: 0.1 W | **Sensor:** power rating: 10 W, voltage rating: max. 175 V (AC/DC), current rating: 0.5 A | **Loop amplifier:** power supply: 12 V DC, power output: max. 20 W, audio inputs: microphone and line (3.5 mm jack and 2- and 3-pin Phoenix connectors), loop output: 2-pin Phoenix connector | **Colors:** Black, Basalt grey, Telegrey, White, custom RAL colors | **Optional:** pushbuttons, language selection switch, engraving, labeling, protective tube | **Accessories:** wall bushing

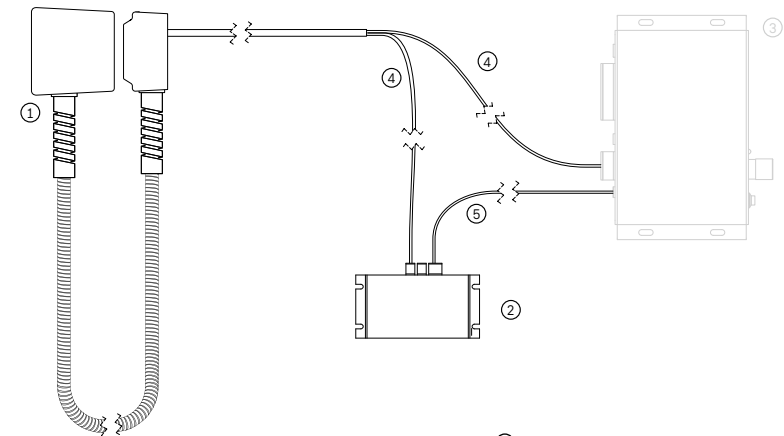

- ① VIA Induction handset
- ② Loop amplifier (AUDIOROPA LA-70)
- ③ Audio source (e.g. AP 01)
- ④ Handset lead
- ⑤ Adapter lead



HANDSET

VIA Tabletop Holder

The VIA Tabletop Holder is ideal for mounting on horizontal or sloping surfaces. The base of the tabletop holder is a sturdy angled plate, which presents the handset in a position facing the user. It is made of metal and is coated in the colors Black or Basalt grey. It can be combined with any VIA handset top made of either plastic or aluminum.

The VIA itself is held to its base by a strong magnet. When it is removed from the base, the audio starts playing automatically by activation of the reed contact. When replaced on the base, the playback stops. Optionally integrated pushbuttons or rocker switches in the housing cover can be used for functions like selecting between two languages or navigating through menus. An induction loop for direct transmission of the audio signal into induction-compatible hearing aids can be installed in all non-metallic housings. Engravings or stickers on the housing cover can be used to label these options.

A robust, flexible, stainless steel tube protects the connection cable and reliably secures the handset. Cable retraction is by means of a weight moving vertically downward. If the installation space under the VIA tabletop holder does not allow this, a controlled cable return mechanism, with roller guidance and spring support, is also possible. We would be happy to advise you to find the optimal solution for your project.

Flexible metal tube: length: 125 cm, dia.: 8 mm | **Connection cable:** length: 240 cm | **Weight:** (without tabletop holder or protective tube) 170 g | **Speaker:** impedance: 32 Ω , max. power capacity: 0.1 W | **Sensor:** power rating: 10 W, voltage rating: max. 175 V (AC/DC), current rating: 0.5 A | **Holder colors:** Black, Basalt grey | **VIA color:** all versions in plastic or aluminum | **Optional:** pushbuttons, language selection switch, engraving, labeling, protective tube | **Accessories:** wall bushing

GALLERY —
EXAMPLE INSTALLATIONS



**GALLERY —
EXAMPLE INSTALLATIONS**

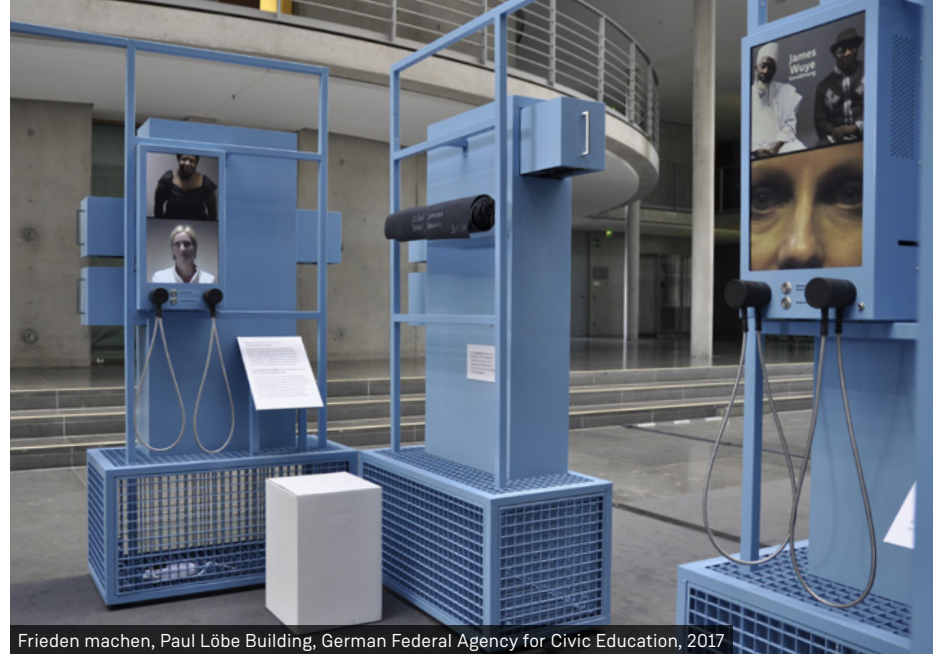

Frieden machen, Paul Löbe Building, German Federal Agency for Civic Education, 2017



Ein JAHR100 in Schleswig-Holstein. Land. Leute. Leben, Open-Air Museum Molfsee, 2021



Let it shine, Peter Rühmkorf: Ninetieth Anniversary, Altonaer Museum, Arno Schmidt Stiftung, 2019

GALLERY —
EXAMPLE INSTALLATIONS



Horst Janssen!?, Oldenburg, 2020



Horst Janssen!?, Oldenburg, 2020

USO

— THE RELIABLE INDIVIDUALIST

The USO handset is a trusted mainstay of molitor's handset range. It is available in a variety of colors and materials, can be produced in custom designs, and offers suitable solutions for various installation situations: for wall mounting, installation in furniture, or as a table-top device.

Thanks to its compact design, this handset is particularly robust and resistant to impacts

and breakage, and is comfortable to hold. The standard housing is made of PVC. Housings made of aluminum can be used untreated, or refined with an anodized finish. Regardless of the material, the back of the handset can be labeled by stickers or engraving.

The USO is held on its base by a strong magnet. When taken off its base, the audio starts playing automatically by activation of the reed contact.

When replaced on the base, the playback stops. Optionally, the handsets can be equipped with a toggle switch or pushbutton for choosing between two languages or different audio tracks.

A robust, flexible, stainless steel tube protects the connection cable and reliably secures the handset. The housings can be cleaned with a damp cloth or disinfectant.



HANDSET

USO Basic

The USO handset combines high-quality technology with an attractive, sturdy design. Its compact design and soft-looking PVC plastic make it comfortable to hold and particularly resistant to impacts and breakage. That and its excellent sound properties have made it a trusted accessory of museums and exhibitions for many years.

The handset is held on its base by a strong magnet. It can be lifted off in any direction, and finds its way securely back to its original position even if not positioned precisely. When picked up, the audio starts playing automatically by activation of the reed contact. When replaced on the base, the playback stops. Optionally, a rocker switch or pushbutton can be integrated into the housing lid, to switch between two languages or to play different tracks.

In the basic PVC version, the USO is available in the colors Black, Dark grey, and White. The included cable is available in different lengths, and is especially durable thanks to its flexible steel tube.

Flexible metal tube: length: 125 cm, dia.: 8 mm | **Connection cable:** length: 240 cm | **Weight:** (without base or protective tube) 220 g | **Speaker:** impedance: 32 Ω , max. power capacity: 0.1 W | **Sensor:** power rating: 10 W, voltage rating: max. 175 V (AC/DC), current rating: 0.5 A | **Colors:** Black, White, Dark grey | **Optional:** pushbutton, engraving, labeling, language selection switch, protective tube | **Accessories:** wall bushing, wall socket with 90° cable routing





HANDSET

USO Metal Version

The USO handset combines high-quality technology with an attractive, sturdy design. The earpiece is compact and made from aluminum, making it comfortable to hold. It can be cleaned optimally, and is also resistant to impacts and breakage. That and its excellent sound properties have made it a trusted accessory of museums and exhibitions for many years.

The handset is held on its base by a strong magnet. It can be lifted off in any direction, and finds its way securely back to its original position even if not positioned precisely. When picked up, the audio starts playing automatically by activation of the reed contact. When replaced on the base, the playback stops. Optionally, a rocker switch or pushbutton can be integrated into the housing lid, to switch between two languages or to play different tracks.

The standard handset comes in a natural aluminum finish. For custom versions, the handset can be anodized in 20 different colors. The included cable is 1.25 m long, and is especially durable thanks to its flexible steel tube.

Flexible metal tube: length: 125 cm, dia.: 8 mm | **Connection cable:** length: 240 cm | **Weight:** (without base or protective tube) 220 g | **Speaker:** impedance: 32 Ω, max. power capacity: 0.1 W | **Sensor:** power rating: 10 W, voltage rating: max. 175 V (AC/DC), current rating: 0.5 A | **Colors:** natural aluminum, anodized aluminum in 20 colors | **Optional:** pushbutton, engraving, labeling, language selection switch, protective tube | **Accessories:** wall bushing, wall socket with 90° cable routing

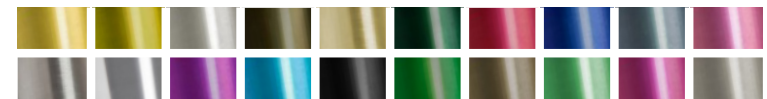



HANDSET

USO With Tabletop Holder and spring-loaded cable retraction with roller guide

The USO handset combines high-quality technology with an attractive, sturdy design. The earpiece is compact and made from PVC plastic. The handset is comfortable to hold, can be cleaned optimally, and is also resistant to impacts and breakage. That and its excellent sound properties have made it a highly trusted accessory of museums and exhibitions.

The handset is held on its base by a strong magnet. It can be lifted off in any direction, and finds its way securely back to its original position even if not positioned precisely. When picked up, the audio starts playing automatically by activation of the reed contact. When replaced on the base, the playback stops. Optionally, a rocker switch or push-button can be integrated into the housing lid, to switch between two languages or to play different tracks.

For discreet immersion of the handset in the exhibition architecture and to protect it from damage, the design with cable retraction is recommended. The roller-guided and spring-loaded retraction is suitable for longer cables and for installations where the space available below the tabletop holder is limited.

The standard model offers a choice of colors between Black, Dark grey, and White.

Flexible metal tube: length: 125 cm, dia.: 8 mm | **Connection cable:** length: 240 cm | **Weight:** (without tabletop holder or protective tube) 170 g | **Speaker:** impedance: 32 Ω, max. power capacity: 0.1 W | **Sensor:** power rating: 10 W, voltage rating: max. 175 V (AC/DC), current rating: 0.5 A | **Holder colors:** Black, White, Dark grey | **USO color:** all colors of the plastic or aluminum models | **Optional:** pushbutton, language selection switch, engraving, labeling, protective tube

GALLERY —
EXAMPLE INSTALLATIONS



GALLERY —
EXAMPLE INSTALLATIONS



Destiny: Master Race. NS Ordensburg between fascination and crime, Vogelsang, 2016

GALLERY —
EXAMPLE INSTALLATIONS



Jewish Museum, Frankfurt, 2020, photo: Norbert Miguletz © Jewish Museum Frankfurt



Conspiracy Theories - Past and Present, Stiftung Kloster Dalheim, 2019



PLUX

— THE HANDSET FOR A SMALL BUDGET

The PLUX is a cost-effective handset that is particularly suitable for temporary use or projects with a low budget. Its rubber body makes it comfortable to hold, robust, and easy to clean.

The speaker has good audio reproduction quality, optimized for clear transmission of music and speech. A perforated plate protects the technology from damage. The accompanying

cable is 2.10 m long. It is available in different lengths on request, and can be ordered with a jack plug as an option. The included plastic wall mount makes for simple installation.

Cable: length: 210 cm, dia.: 7 mm | **Weight:** 170 g (without cable) |
Material: soft plastic | **Speaker:** impedance: 32 Ω, max. power capacity: 0.1 W



ACCESSORY

Wall Bushing for USO

The wall bushing facilitates precise installation and secures the armored cable for stationary use of the USO handset.



ACCESSORY

VIA / USO Language Selection Switch

The language selection switch in black plastic can be ordered as an option for the VIA and USO handsets. It is used to switch between two languages or audio tracks.

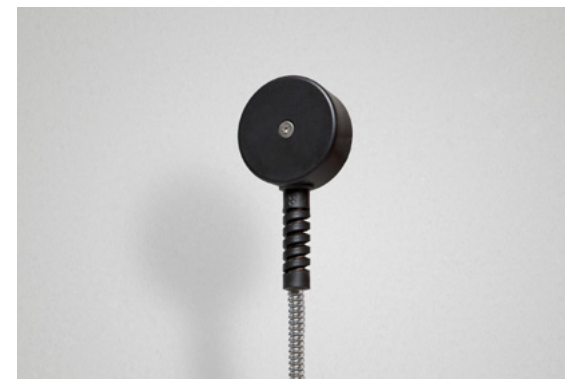

ACCESSORY

Wall Socket with 90° Cable Routing

This wall socket made of black glass-fiber reinforced polyamide with anti-kink cable protector is used to connect USO handsets at a 90° angle. It comes pre-assembled with a protective metal tube.

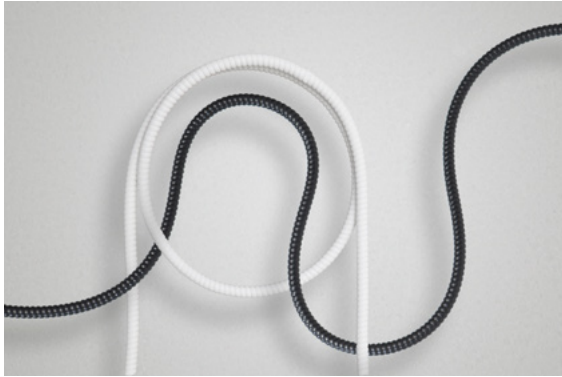

ACCESSORY

VIA / USO Special Protective Tube

The handsets of the VIA and USO series come standard with a robust, uncoated, flexible stainless steel tube. For aesthetic reasons or to protect the sensitive surfaces of exhibition furniture from scratching, it may be advisable to use a protective tube with PVC sheathing. We offer this tube in the colors White and Black.



ACCESSORY

USO/VIA/PLUX Jack Plug

Preassembled connection cable with audio jack plug.
Connector: 3.5 mm jack plug.



ACCESSORY

Jack Adapter

This adapter can be used to connect our preassembled 3.5 mm jack plug to 6.5 mm audio sources.



HEADPHONES

EXKLUSIVE SOUND

If you want recordings to be heard in high quality without broadcasting them to entire rooms, headphones are your best option. The closed design of our headphones shields the ear from the outside, shutting out disruptive ambient noise. At the same time, they reduce the emission of sound to the outside, preventing aural disturbance to bystanders. The closed air space between the ear and the headphones also produces more powerful bass, a further advantage

of this design. These aspects are fundamental in the use of audio in public spaces and exhibitions. At the same time, such environments impose special requirements on equipment. To meet the daily demands of museums, we supply our headsets in a very robust, wipeclean design. In the event that parts wear out or need to be replaced for hygiene reasons, they can be ordered separately and are easy to replace.



HEADPHONES DIO

The DIO headphones are specially adapted to the requirements of exhibitions, trade show booths, and sales installations. Their functional and sturdy construction is designed for continuous operation, and ensures a long service life. The mini jack plug allows immediate operation with most audio sources. The earpiece width is adjustable to ensure a good fit, and can be quickly and conveniently adjusted directly on the head. The ear pads, headband pads, and adjustment units are available separately and can be replaced.

Flexible metal tube: length: 1.15 m / 1.5 m; dia.: 7 mm | **Connection:** 3.5 mm mini jack (stereo, straight) | **Weight:** 220 g (without cable) | **Speaker:** impedance: 35 Ω , max. power capacity: 0.1 W | **Accessories:** wall bushing, wall mount, jack adapter





HEADPHONES

DIO With Spiral Cable

The DIO headphones with spiral cable are specially adapted to the requirements of exhibitions, trade show booths, and sales installations. Their functional and sturdy construction is designed for continuous operation, and ensures a long service life. The light, flexible spiral cable is especially suitable for installations where space is limited, or on sensitive exhibition furniture. The mini jack plug allows immediate operation with most audio sources. The DIO also includes a screw-on jack adapter for 6.3 mm sockets. The earpiece width is adjustable to ensure a good fit, and can be quickly and conveniently adjusted directly on the head. The ear pads, headband pads, and adjustment units are available separately and can be replaced.

Spiral cable: length: 1.3-3 m; dia.: 7 mm | **Connection:** 3.5 mm mini jack (stereo, straight) + screw-on jack adapter for 6.3 mm | **Weight:** 220 g (without cable) | **Speaker:** impedance: 35 Ω , max. power capacity: 0.1 W | **Accessories:** wall mount



HEADPHONES

DIO With Fabric Cable

Including Volume Control and Microphone

The DIO headphones are specially adapted to the requirements of exhibitions, trade show booths, and sales installations. The fabric cable incorporates a rotary controller for volume control of the headphones, and a microphone. The functional and sturdy construction of these headphones is designed for continuous operation, and ensures a long service life. The mini jack plug allows immediate operation with most audio sources. Low impedance of 35 Ω ensures high efficiency.

Fabric cable: length: 2 m | **Connection:** 3.5 mm mini jack (stereo, straight) | **Weight:** 220 g (without cable) | **Speaker:** impedance: 35 Ω , max. power capacity: 0.1 W | **Accessories:** wall mount





HEADPHONES DIO

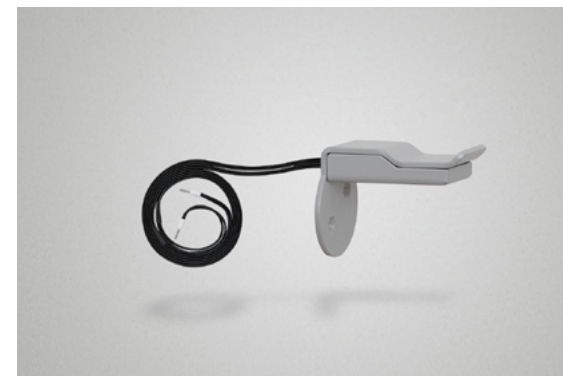

HEADPHONES

DIO With Auto Start Function and Wall Mount

The DIO headphones with auto start function (reed function) and wall mount are a complete package specially adapted to the requirements of exhibitions, trade show booths, and sales installations. Their sturdy construction is designed for continuous operation, and ensures a long service life. The reed function allows the connected audio or media player to be started or stopped simply by picking up and putting down the headband on its holder. There are no superfluous buttons or disruptive operating menus.

Flexible metal tube: length: 1.15 m / 1.5 m; dia.: 7 mm | **Connection:** 3.5 mm mini jack (stereo, straight) | **Weight:** 220 g (without cable) | **Speaker:** impedance: 35 Ω , max. power capacity: 0.1 W | **Color of the wall mount:** ■ Black grey □ Signal white ■ White aluminium | **Accessories:** wall bushing, jack adapter



HEADPHONES MIO



SINGLE-EAR HEADSET

MIO

Just like DIO, our MIO headphones are specially adapted to the requirements of exhibitions, trade show booths, and sales installations. Their functional and sturdy construction is designed for continuous operation, and ensures a long service life. The mini jack plug allows immediate operation with most audio sources. The specialized design of the MIO makes this headset especially suitable for situations where users need to have both hands free while listening, without losing contact with their surroundings. Equipped with only one earcup, the headset is held securely in place by the headband and the temple pad. The ear pads, headband pads, and adjustment units are available separately and can be replaced.

Flexible metal tube: length: 1.15 m / 1.5 m; dia.: 7 mm | **Connection:** 3.5 mm mini jack (stereo, straight) | **Weight:** 290 g (including cable) | **Speaker:** impedance: 35 Ω , max. power capacity: 0.1 W | **Accessories:** wall bushing, wall mount, jack adapter

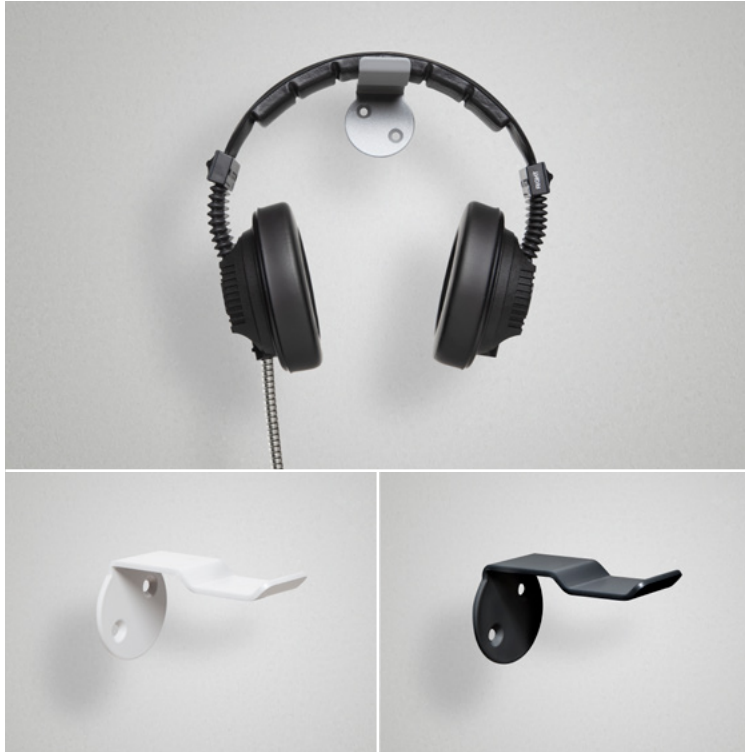

ACCESSORY
Wall Mount

Secure support is provided by this wall mount, specially developed for the DIO and MIO headphones.

Color: ■ Black grey □ Signal white ■ White aluminium | **Material:** stainless steel



ACCESSORY
Hygienic cover

To ensure hygienic use of our DIO and MIO headphones at their many places of use in exhibitions, trade shows, and sales installations, we offer a lightweight cover made of nonwoven fabric in black and white. Fitted with an elastic band, it can be pulled quickly and easily over the earpieces and replaced as required.

Colors: ■ Black □ White | **Material:** Nonwoven fabric



ACCESSORY
Wall Duct

The wall duct provides strain relief for cables and facilitates precise installation. This robust, discreet component holds the flexible metal tube firmly in place for stationary use of the headphones.

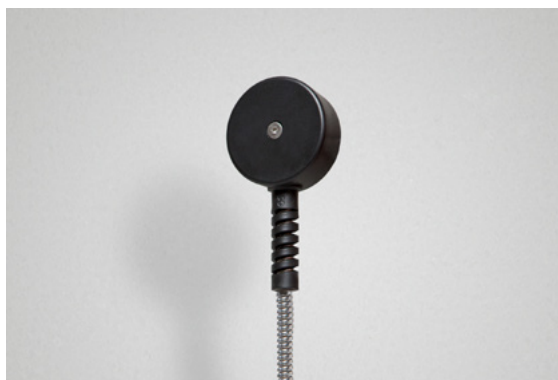

ACCESSORY
Wall Socket with 90° Cable Routing

This wall socket, made of black glass-fiber reinforced polyamide with anti-kink cable protector, is used to connect headphones at a 90° angle. It comes pre-assembled with a protective metal tube.

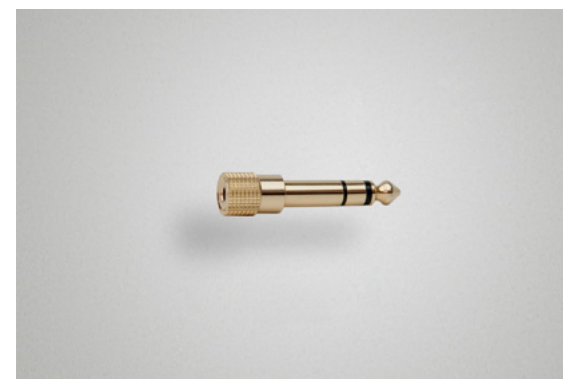

ACCESSORY
Jack Adapter

For use with the DIO and MIO headphones with flexible metal tube, this 6.3 mm jack adapter permits versatile connection to additional audio sources.

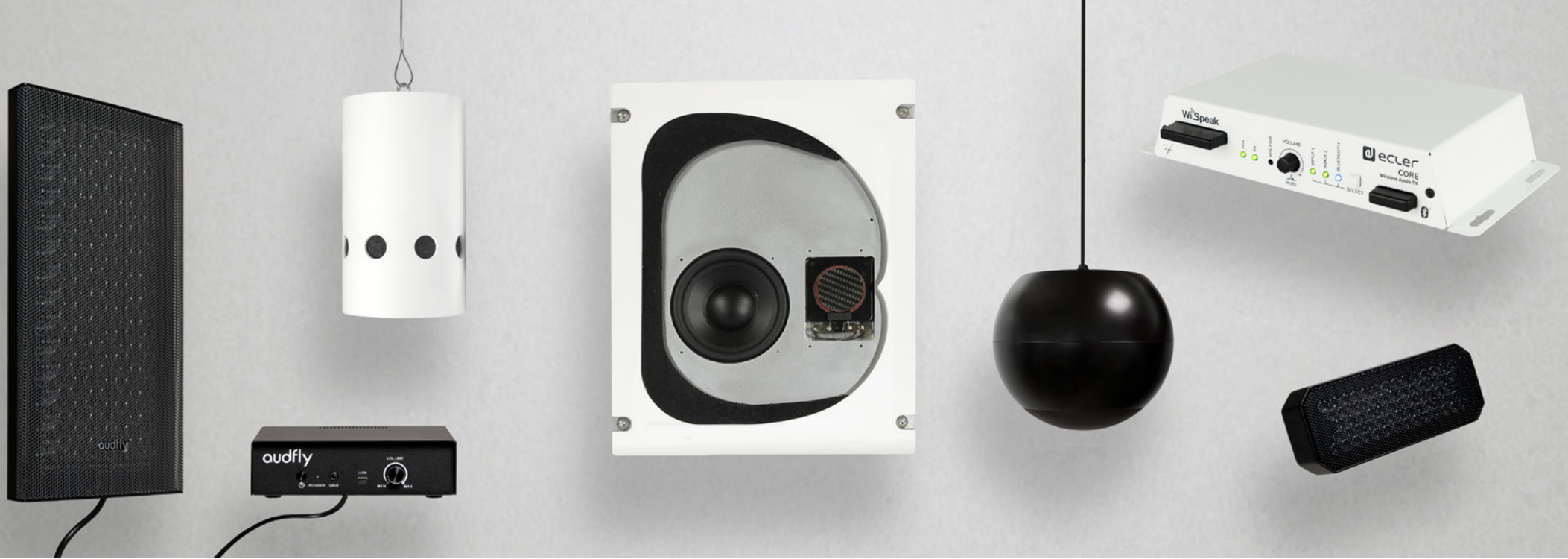

LOUDSPEAKERS

— FOR DIVERSE ACOUSTIC REQUIREMENTS

Our specially selected loudspeaker systems are designed for sound reinforcement in open areas, and also for focused listening in defined spaces. Based on your specific requirements, you can choose from a range of different speaker types, which vary in terms of shape, technical features, and mounting.

To achieve optimal sound irradiation, each loudspeaker system has to be matched to the acoustics of the particular space. The crucial factors here are the sound characteristics of

the speakers and the nature of the surrounding surfaces. We work together with respected manufacturers to ensure the quality of our loudspeakers. To help you find the best system for your venue, we are happy to provide comprehensive advice.

All our speaker systems can be combined with our players, and excel in terms of their versatility, robustness, and practicality. They can be activated by motion detectors and other sensors, thus permitting contact-free operation.



ULTRASONIC DIRECTIONAL SPEAKER **molitor FSC 1**

The molitor FSC1 is our mid-sized ultrasonic directional speaker. It was developed for targeted radiation of sound to a confined listening zone with one to two listeners at a distance of about 4 to 5 meters from the speaker. It is ideal for use in museums, where it benefits from the relatively quiet environment. A special amplifier comes included.

It works very well in combination with our interactive media players such as the AP01 and MP01. The sensors built into these players detect whether someone is in the target area, and only then start playback.

For optimal use of this type of speaker, it is important to consider the characteristics of the room and adapt them if necessary to achieve the desired acoustics. We are happy to provide consultation for this purpose.

Power supply: 24 VDC, 3 A | **Maximum power consumption:** 35 W |
Dimensions: speaker: 292 × 163 × 23 mm (W × D × H); amplifier: 111 × 111 × 33 mm (W × D × H) | **Weight:** speaker: 840 g; amplifier: 600 g |
Maximum SPL: 85 dB at 1 kHz/2 m | **Frequency range:** 300 Hz-8 kHz |
Directional pattern: <10° (-10 dB)



ULTRASONIC DIRECTIONAL SPEAKER **molitor FS-Mini**

The molitor FS-Mini is the smallest of our directional ultrasonic speakers. It offers an effective way of putting sound exactly where you want it. Its compact design allows discreet installation even in tight spaces. A built-in amplifier can be used to connect and operate any audio source directly. It works very well in combination with our interactive media players such as the AP01 and MP01. In combination with a sensor, these can start playing the relevant content as soon as someone enters the room.

For optimal use of this type of speaker, it is important to consider the characteristics of the room and adapt them if necessary to achieve the desired acoustics. We are happy to provide consultation for this purpose.

Power supply: 12 V DC, 2 A | **Maximum power consumption:** 24 W |
Dimensions: 170 × 70 × 40 mm (W × D × H) | **Weight:** 317 g | **Maximum SPL:** 70 dB at 1 kHz/2 m | **Frequency range:** 300 Hz-8 kHz | **Directional pattern:** <math>< 15^\circ</math> (-10 dB)

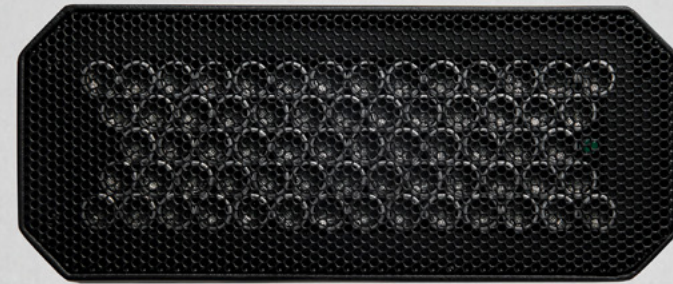

ACCESSORY

Wall bracket for molitor FS-Mini

The wall bracket for installing the molitor FS-Mini ultrasonic directional speaker consists of a mounting plate plus a two-part holding device that securely clasps the speaker. The plate is screwed onto a wall or ceiling, and the speaker can then be directed accordingly using the tilt mechanism.

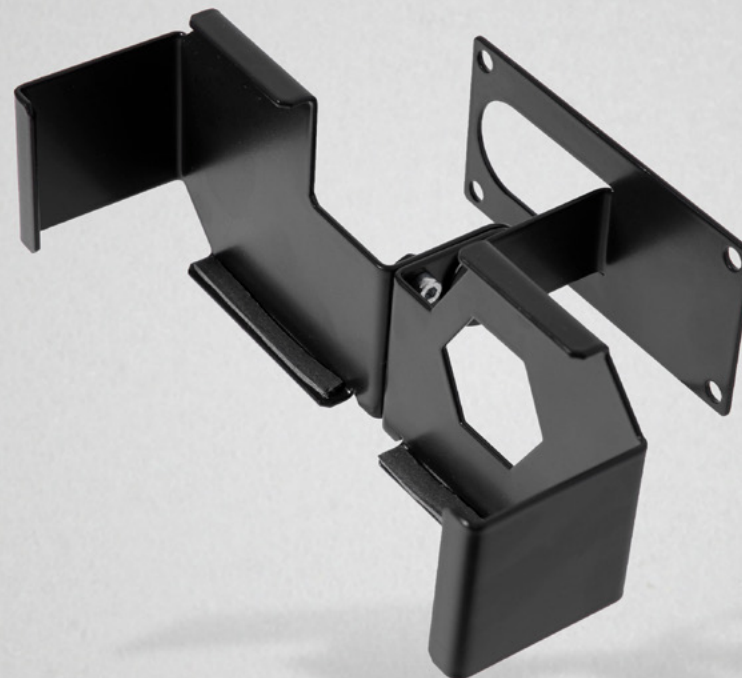
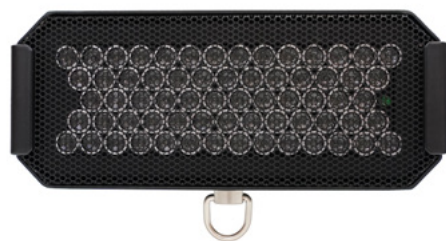



ULTRASONIC DIRECTIONAL SPEAKER **molitor audiospotlight system 16,8"**

This directional ultrasonic loudspeaker is ideal for radiation of sound to highly confined areas. This allows audio to be addressed to individual people at precisely defined locations. For this purpose, the rooms should be quiet and the audio tracks should be in relatively high frequency ranges. This works perfectly in quiet museums where open ambient sound is desired without disturbing bystanders.

The system comes with an integrated amplifier, as well as a media player with a microSD card for data storage. You therefore receive a complete system in one. However, you can still connect your own audio source if needed. The VESA100 mounting system allows easy installation wherever you require. The audiospotlight is also compatible with many standard mounts.

For optimal use of this type of speaker, it is important to consider the characteristics of the room and adapt them if necessary to achieve the desired acoustics. We are happy to provide consultation for this purpose.

Power supply: 24 VDC, 2 A | **Maximum power consumption:** 1 W |
Dimensions: 400 × 200 × 35 mm (W × D × H) | **Weight:** 1.1 kg |
Maximum SPL: 80 dB at 1 kHz | **Directional pattern:** <10 % (-20 dB)

DIRECTIONAL SPEAKER WITH SUPERCARDIOID PATTERN

RL 110

The directional loudspeakers in the RL 110 series are sharply focused, compact cylindrical speakers designed for use in museums, exhibitions, and presentation spaces. Their special design with sound outlets arranged in a ring in the speaker box creates a supercardioid pattern over the entire frequency range.

The RL 110 series can thus be used to project sound into targeted listening zones where speech is reproduced with outstanding clarity, while keeping sound emissions to neighboring areas to very low levels.

For installation, the speaker is either suspended from the ceiling by a steel cable, such as the SR 300, or fastened to a wall or ceiling using the rotating and pivoting WH 110 bracket. For optimum sound results, the distance between the speaker and the listener should be as short as possible.

Operating principle: full range directional speaker with supercardioid pattern, with electronic frequency response linearization | **Components:** 3" full range driver | **Frequency range:** 190 Hz–19 kHz | **Impedance:** 8 Ω | **Power capacity:** 20 W RMS, 40 W program | **Sensitivity and SPL:** 83 dB (1 W/1 m), max. SPL 96 dB, 100 V version: max. SPL 93 dB | **Dispersion angle:** 80° | **Dimensions:** d = 110 mm, L = 190 mm | **Weight:** 1.0 kg | **Fastening points:** suspension point at rear, M4, with eyebolt included; lateral threaded insert, M6, for optional bracket WH 110 | **Box:** aluminum, front: powder-coated fine-perforation grille | **Connections:** screw-type terminals, pluggable | **Warranty:** 5 years



ACTIVE DIRECTIONAL SPEAKER WITH SUPERCARDIOID PATTERN RL 110 A

The RL 110 A model is an active loudspeaker with 20 watts output, automatic switch-on, and a supercardioid directional pattern over the entire frequency range. Like the rest of this range, it was developed for focused acoustic irradiation in confined listening areas.

The necessary ports and controls are located on the back of the box. These include the stereo RCA input jacks, the DIP switch for auto ON/steady ON and 150 Hz high-pass filter, the volume control, the power LED, and the socket for the external power supply unit. The speaker's high input sensitivity of -6 dBu allows it to be connected directly to an MP3 player or a computer.

For installation, the one-kilogram active loudspeaker can either be suspended from a ceiling or mounted on a wall or ceiling using the rotating and pivoting WH 110 bracket. For optimum sound results, the distance between the speaker and the listener should be as short as possible.

Operating principle: active directional speaker with supercardioid pattern | **Components:** 3" full range driver | **Frequency range:** 190 Hz-19 kHz | **Amplifier output:** 20 W | SPL: max. 95 dB | **Dispersion angle:** 80° | **Connections:** stereo RCA input | **Input sensitivity:** -6 dBu for full modulation, input impedance 10 kΩ | **Controls:** volume, switch for auto ON/steady ON, switchable 150 Hz high-pass filter, LED for power ON | **Power supply:** 15 V DC power pack included in delivery | **Supply voltage:** 90-240 V AC | **Dimensions:** d = 110 mm, L = 190 mm | **Weight:** 1.0 kg | **Fastening points:** suspension point at rear, M4, with eyebolt included; lateral threaded insert, M6, for optional bracket WH.110 | **Box:** aluminum, front: powder-coated fine-perforation grille | **Warranty:** 5 years



ACTIVE DIRECTIONAL SPEAKER WITH MP3 PLAYER

RL 110 A-MP3

The RL 110 A-MP3 model comes with an additional integrated MP3 player with Bluetooth receiver. The MP3 player plays audio files from a microSD card, USB drives, or via a Bluetooth connection. It automatically switches between the signal sources. In addition to the internal MP3 player, an external media player or computer can also be connected to the stereo RCA input.

All the necessary ports and controls are located on the back of the box. These are the stereo RCA input jacks, the DIP switch for auto ON/steady ON and 150 Hz high-pass filter, the volume control, the power LED, and the socket for the external power supply unit.

For installation, the compact speaker can either be suspended directly from a ceiling or fastened to a wall or ceiling using the L-bracket WH 110. For optimum sound results, the distance between the speaker and the listener should be as short as possible.

Operating principle: active directional speaker with supercardioid pattern | **Components:** 3" full range driver | **Frequency range:** 190 Hz-19 kHz | **Amplifier output:** 20 W | SPL: max. 95 dB | **Dispersion angle:** 80° | **Connections:** stereo RCA input | **Input sensitivity:** -6 dBu for full modulation, input impedance 10 kΩ | **Controls:** volume, switch for auto ON/steady ON, switchable 150 Hz high-pass filter, LED for power ON | **MP3 player:** plays MP3 and WAV files from microSD, USB, or via Bluetooth; priority 1 = microSD, priority 2 = USB, priority 3 = Bluetooth | **Power supply:** 15 V DC power pack included in delivery | **Supply voltage:** 90-240 V AC | **Dimensions:** d = 110 mm, L = 190 mm | **Weight:** 1.0 kg | **Fastening points:** suspension point at rear, M4, with eyebolt included; lateral threaded insert, M6, for optional bracket WH 110 | **Box:** aluminum, front: powder-coated fine-perforation grille | **Warranty:** 5 years



ACTIVE DIRECTIONAL SPEAKER WITH MOTION SENSOR

RL 110 AX

The RL 110 AX is an active directional loudspeaker with a supercardioid directional pattern for focused acoustic irradiation of confined listening zones, and an integrated motion sensor. It switches itself on automatically as soon as anyone approaches it from the front, and plays an audio file from an external MP3 player. There is a dry contact available for control of the external media player. The user can choose between four operating modes and a playback time of 1 to 1024 seconds:

PLAY ONCE: The entire audio file is played and can only be restarted once it is finished. **EXTEND:** The playing time of the audio file is extended every time a new movement is detected. **ONLY SPEAKER SWITCHED:** The ON time of the speaker is extended every time movement is detected. The motion sensor switches only the speaker on and off, not the external device. **CONTINUOUS:** The audio file is played continuously.

The external media player or computer can be connected directly to the stereo RCA input. The integrated amplifier has an output of 20 watts and an automatic switch-on feature (Auto ON/OFF). All the controls, including the volume control, power LED, and jacks, are located on the back of the box.

For installation, the compact speaker can either be suspended directly from a ceiling or fastened to a wall or ceiling using the L-bracket WH 110. For optimum sound results, the distance between the speaker and the listener should be as short as possible.

Operating principle: active full range directional speaker with supercardioid pattern, with integrated motion sensor | **Components:** 3" full range driver | **Frequency range:** 190 Hz–19 kHz | **Amplifier output:** 20 W | **SPL:** max. 95 dB | **Dispersion angle:** 80° | **Connections:** stereo RCA input, switching contact for external media player | **Input sensitivity:** -6 dBu for full modulation, input impedance 10 kΩ | **Controls:** volume, switch for auto ON/steady ON, switchable high-pass filter, LED for power ON, switch for operating modes: PLAY FILE ONCE, EXTEND PLAY, ONLY SPEAKER SWITCHED, CONTINUOUS, DIP switch to set the hold time (1–1024 sec.) | **Power supply:** 15 V DC power pack for 230 V AC included in delivery | **Dimensions:** d = 110 mm, L = 190 mm | **Weight:** 1.4 kg | **Fastening points:** suspension point at rear, M4, with eyebolt included; lateral threaded insert, M6, for optional bracket WH110 | **Box:** aluminum, front: powder-coated fine-perforation grille | **Warranty:** 5 years



ACTIVE DIRECTIONAL SPEAKER WITH MOTION SENSOR AND MP3 PLAYER RL 110 AX-MP3

The RL 110 AX-MP3 model features an additional integrated MP3 player with Bluetooth receiver. It plays audio files from a microSD card, USB drive, via Bluetooth, or via the stereo RCA input. There is a dry contact available for control of an external media player. As with the RL 110 AX, the user can choose between four operating modes and a playback time of 1 to 1024 seconds:

PLAY ONCE: The entire audio file is played and can only be restarted once it is finished. **EXTEND:** Speaker activity is extended every time a new movement is detected. **ONLY SPEAKER SWITCHED:** The ON time of the speaker is extended every time movement is detected. The MP3 player plays the audio file in an endless loop in the background, with only the speaker being switched on and off by the motion sensor. **CONTINUOUS:** Continuous operation.

The external media player or computer can be connected directly to the stereo RCA input. The integrated amplifier has an output of 20 watts and an automatic switch-on feature (Auto ON/OFF). All the controls, including the volume control, power LED, and jacks, are located on the back of the box.

For installation, the compact directional speaker can either be suspended directly from a ceiling or fastened to a wall or ceiling using our L-bracket WH 110.

Operating principle: active full range directional speaker with supercardioid pattern, with integrated motion sensor, MP3 player, and Bluetooth receiver | **Components:** 3" full range driver | **Frequency range:** 190 Hz–19 kHz | **Amplifier output:** 20 W | **SPL:** max. 95 dB | **Dispersion angle:** 80° | **Connections:** stereo RCA input, switching contact for external media player, operation in parallel to internal player | **Input sensitivity:** -6 dBu for full modulation, input impedance 10 kΩ | **Controls:** volume, switch for auto ON/steady ON, switchable high-pass filter, LED for power ON, switch for operating modes: PLAY FILE ONCE, EXTEND PLAY, ONLY SPEAKER SWITCHED, CONTINUOUS, DIP switch to set the hold time (1–1024 sec.) | **MP3 player:** plays MP3 and WAV files from microSD, USB, or via Bluetooth; priority 1 = microSD, priority 2 = USB, priority 3 = Bluetooth | **Power supply:** 15 V DC power pack included in delivery | **Supply voltage:** 90–240 V AC | **Dimensions:** d = 110 mm, L = 190 mm | **Weight:** 1.4 kg | **Fastening points:** suspension point at rear, M4, with eyebolt included; lateral threaded insert, M6, for optional bracket WH110 | **Box:** aluminum, front: powder-coated fine-perforation grille | **Warranty:** 5 years



ACTIVE DIRECTIONAL LOUDSPEAKER WITH AUTOMATIC VOLUME CONTROL

RL 110 perZonic®

The RL 110 perZonic® is a directional loudspeaker with automatic volume control. It adjusts the reproduction volume according to the ambient noise. This allows it to always reach the required volume in the listening zone in situations with fluctuating audience numbers, while preventing the volume from becoming disruptive in quieter surroundings. For this purpose, a microphone on the back continuously measures the ambient noise, which is then applied as a process variable for the foreground audio. The degree of regulation can be set to anywhere from 0% to 100%, as can the attack and release times of the regulation.

This ensures maximum clarity in the listening zone and minimum disruption to personnel and visitors nearby. This makes it ideal for use in museums, exhibitions, trade shows, and areas where people circulate.

All the ports and controls are located on the back of the box, along with the mono RCA input, the power LED, and the socket for the external power supply unit. High input sensitivity of -6 dBu allows direct connection to an MP3 player or computer.

For installation, the speaker can either be suspended from a ceiling or fastened to a wall or ceiling using the L-bracket WH 110. For optimum results, the distance between the speaker and the listener should be as short as possible.

Operating principle: active full range directional speaker with supercardioid pattern and automatic volume control according to ambient noise | **Components:** 3" full range driver | **Frequency range:** 190 Hz-19 kHz | **Amplifier output:** 20 W | **SPL:** max. 95 dB | **Dispersion angle:** 80° | **Connections:** mono RCA input | **Input sensitivity:** -6 dBu for full modulation, input impedance 10 kΩ | **Controls:** controls for volume, regulation (0-100%), attack time, release time, LED for power ON | **Power supply:** 15 V DC power pack included in delivery | **Dimensions:** d = 110 mm, L = 190 mm | **Weight:** 1.4 kg | **Fastening points:** suspension point at rear, M4, with eyebolt included; lateral threaded insert, M6, for optional bracket WH 110 | **Box:** aluminum, front: powder-coated fine-perforation grille | **Warranty:** 5 years



DIRECTIONAL SPEAKER FOR VOICE ALARM SYSTEMS

RL 180 NT EVAC

The RL 180 NT EVAC is a 2-way speaker for suspension from ceilings in rooms with long reverberation times. The proven Polar® technology produces a consistently wide dispersion angle at medium and high frequencies. The cardioid pattern effectively suppresses disruptive sound reflections from the ceiling by minimizing the amount of sound emitted backwards at low frequencies. As such, a small number of identical speakers can be used to transmit speech very evenly and clearly, even in acoustically challenging rooms.

Due to these properties, it is also certified as a loudspeaker for voice alarm systems in indoor areas in accordance with EN 54-24. The speakers are especially beneficial in public buildings with high visitor numbers: Specific instructions for action can help prevent mass panic in the event of an alarm.

For installation, the speaker can either be suspended from a ceiling or fastened to a wall or ceiling using the matching WH 180 bracket.

Operating principle: 2-way directional speaker with Polar technology and cardioid pattern. Certified in accordance with EN 54-24:2008 – loudspeakers for voice alarm systems, type A (indoor areas) | **Components:** 6.5" woofer + 1" dome tweeter | **Frequency range:** 120 Hz-20 kHz | **Power capacity:** 100 V, 30/15/7.5 W | **Sensitivity:** 77 dB (1 W/4 m) | **Maximum SPL:** 94 dB (30 W/4 m) | **Dispersion angle:** 160° | **Connections:** screw-type terminals, pluggable up to 2.5 mm², cover with PG 11 cable gland | **Dimensions:** d = 180 mm, L = 280 mm | **Weight:** 3.4 kg | **Fastening points:** suspension point at rear, M8, with eyebolt included; lateral threaded insert, M10 (for WH180) | **Box:** aluminum, front: powder-coated fine-perforation grille | **Warranty:** 5 years





CYLINDRICAL SPEAKER FOR GENERAL SOUND REPRODUCTION **FZ 110**

The FZ 110 is a small, general-purpose cylindrical installation speaker with an electronically linearized 3" full range driver. This allows its use in museums, exhibitions, the hospitality sector, and also for multimedia systems.

Its neutral sound characteristics mean the FZ 110 can be easily combined with other types of speakers. For especially high quality music reproduction, we recommend combining it with the SUB 20 or SUB 40 subwoofers.

It can be mounted by either suspending it from the ceiling, or screwing it to a wall or ceiling with an appropriate accessory. This compact cylindrical loudspeaker provides a visually appealing alternative especially in areas where built-in loudspeakers cannot be used for architectural reasons. Standard models are available in either black or white.

Operating principle: cylindrical full range speaker, electronically linearized | **Components:** 3" full range driver | **Frequency range:** 110 Hz-19 kHz | **Impedance:** 8 Ω | **Power capacity:** 20 W RMS, 40 W program | **Sensitivity and SPL:** 83 dB (1 W/1 m), max. SPL 96 dB, 100 V version: max. SPL 93 dB | **Dispersion angle:** 120° | **Dimensions:** d = 110 mm, L = 190 mm | **Weight:** 1.0 kg | **Fastening points:** suspension point at rear; lateral threaded insert, M6, for mounting | **Connections:** screw-type terminals, pluggable | **Warranty:** 5 years



CYLINDRICAL SPEAKER WITH WIDE DISPERSION ANGLE **FZ 140 polar**

The FZ 140 Polar is a cylindrical 2-way loudspeaker with Polar technology for wide, even sound dispersion. Due to its optimized box design with a passive radiator on the back, it provides not only a balanced, clear sound pattern, but also outstanding bass response.

With a wide dispersion pattern across the entire frequency range, it can be used to distribute sound very evenly throughout the room, even with just a few speakers.

The speaker can either be suspended from a ceiling or mounted on a wall or ceiling using the L-bracket WH 140. The standard models are available in either black or white.

Operating principle: 2-way cylindrical speaker with Polar technology | **Components:** 4" woofer + 0.75" dome tweeter + 4" passive radiator | **Frequency range:** 55 Hz-20 kHz | **Impedance:** 8 Ω | **Power capacity:** 30 W RMS, 60 W program | **Sensitivity and SPL:** 83 dB (1W/1m), max. SPL 101dB, 100 V version: max. SPL 98 dB | **Dispersion angle:** 160° | **Dimensions:** d = 140 mm, L = 240 mm | **Weight:** 1.8 kg | **Fastening points:** suspension point at rear, M5, with eyebolt included; lateral threaded insert, M8, for optional bracket WH 140 | **Box:** aluminum, front: powder-coated fine-perforation grille | **Connections:** screw-type terminals, pluggable | **Warranty:** 5 years



CYLINDRICAL SPEAKER WITH CONSTANT DIRECTIVITY **FZ 180 CD**

The FZ 180 CD is a cylindrical loudspeaker with a defined dispersion angle of 80°. This highly resilient 2-way system features a 6.5" bass-mid range woofer and a 1" neodymium tweeter and waveguide, plus an optimized box with back-mounted passive radiator. It provides linear, dynamic music reproduction with an extensive bass range.

Its high speech intelligibility and clear music reproduction, even in rooms with long reverberation times, make it especially suitable for use in museums, exhibitions, the hospitality sector, and multimedia systems.

For installation, the speaker can either be suspended from a ceiling or mounted on a wall or ceiling using the L-bracket WH 180. It is then directed appropriately toward the listening area.

Operating principle: 2-way cylindrical speaker with constant directivity | **Components:** 6.5" woofer + 1" waveguide tweeter | **Frequency range:** 60 Hz-20 kHz | **Impedance:** 8 Ω | **Power capacity:** 60 W RMS, 120 W program | **Sensitivity and SPL:** 86 dB (1 W/1 m), max. SPL 108 dB, 100 V version: max. SPL 103 dB | **Dispersion angle:** 80° | **Dimensions:** d = 180 mm, L = 280 mm | **Weight:** 3.8 kg | **Fastening points:** suspension point at rear, M6, with eyebolt included; lateral threaded insert, M10, for optional bracket WH 180 | **Box:** aluminum, front: powder-coated fine-perforation grille | **Connections:** screw-type terminals, pluggable | **Warranty:** 5 years



ACCESSORY

WH 110 / WH 140 / WH 180 Wall bracket for cylindrical and directional speakers

The wall bracket for installation of cylindrical and directional speakers consists of a mounting plate and a rotating and pivoting L-shaped bar. The plate is bolted onto a wall or ceiling, and the speaker can then be aimed as required using the pivot mechanism. The speaker is secured with an accompanying steel cable. The entire system is also available in black and white.

WH 110 compatible with FZ 110 / RL 110

WH 140 compatible with FZ 140 / RL 140

WH 180 compatible with RL 180



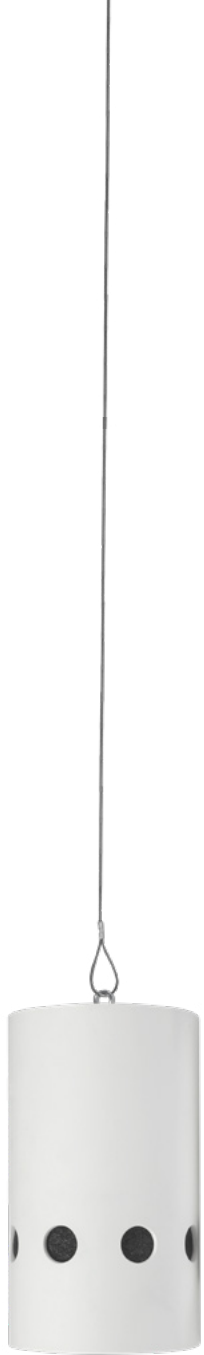

ACCESSORY

SR 300 Steel cable for ceiling suspension

This accessory is a 3 m steel cable which is used to suspend the loudspeaker. The cable is made of stainless steel, with a thickness of 1 mm, and is equipped with a loop on one end.



ACCESSORY

SR 300-16 Steel cable for ceiling suspension

This accessory is a 3 m steel cable used to suspend heavy loudspeakers. The cable is made of stainless steel, with a thickness of 1.6 mm, and is equipped with a loop on one end.

LOUDSPEAKER FOR INVISIBLE INSTALLATION

DE Plan 200®

The DE Plan 200® is a compact, 2-way flat transducer which integrates into walls or ceilings so it is completely invisible. Despite its small dimensions, it impresses with its very wide frequency range and good bass response. The patented design principle of the entire DE Plan series allows uniform deflection of the flat membrane. The de:shape® membrane has an optimized contour with a calculated distribution of distance between the edge and the high frequency driver. This minimizes resonance and achieves extremely accurate reproduction of high frequencies.

The meticulously tuned crossover ensures a warm, clear sound pattern. Even distribution of sound throughout the room is achieved by the wide dispersion angle of 180° - for a level of quality valued in the home audio sector, in museums, exhibitions, audiovisual rooms, and the hospitality sector.

The DE Plan 200 is installed in hollow dry walls and ceilings. In solid walls and concrete ceilings, the EGB Plan 200 back box is also used. After the speaker is installed, the sound-radiating membrane is lined with the accompanying glass fiber fabric, plastered over, and coated with wall paint.

Operating principle: 2-way flat transducer | **Components:** 4" woofer + 1" dome tweeter | **Frequency range:** 70 Hz-20 kHz (built into MDF front panel with 3 mm wall thickness in front of the speaker) | **Impedance:** 8 Ω | **Power capacity:** 40 W RMS, 80 W program | **Sensitivity and SPL:** 81 dB (1 W/1 m), max. SPL 99 dB, 100 V version: max. SPL 95 dB | **Dispersion angle (H × V):** 180° | **Speaker dimensions:** speaker: 300 × 240 × 72 mm; with mounting feet: 300 × 310 mm | **Cutout size:** 304 × 244 mm (wall thickness 10-35 mm including back box) | **Installed depth:** 72 mm | **Weight:** 2.8 kg | **Connections:** screw-type terminals, pluggable | **Warranty:** 5 years

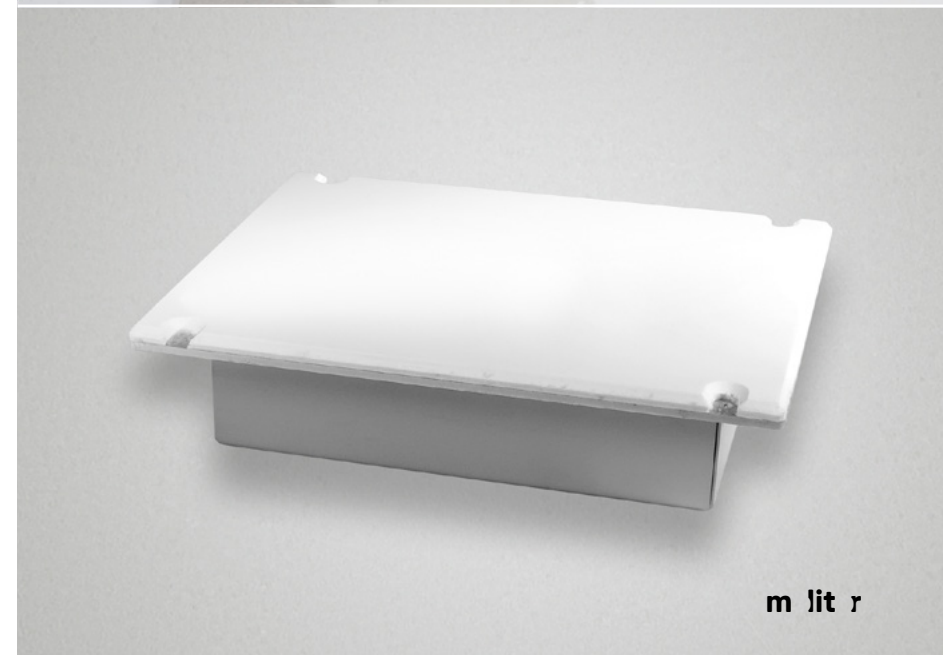
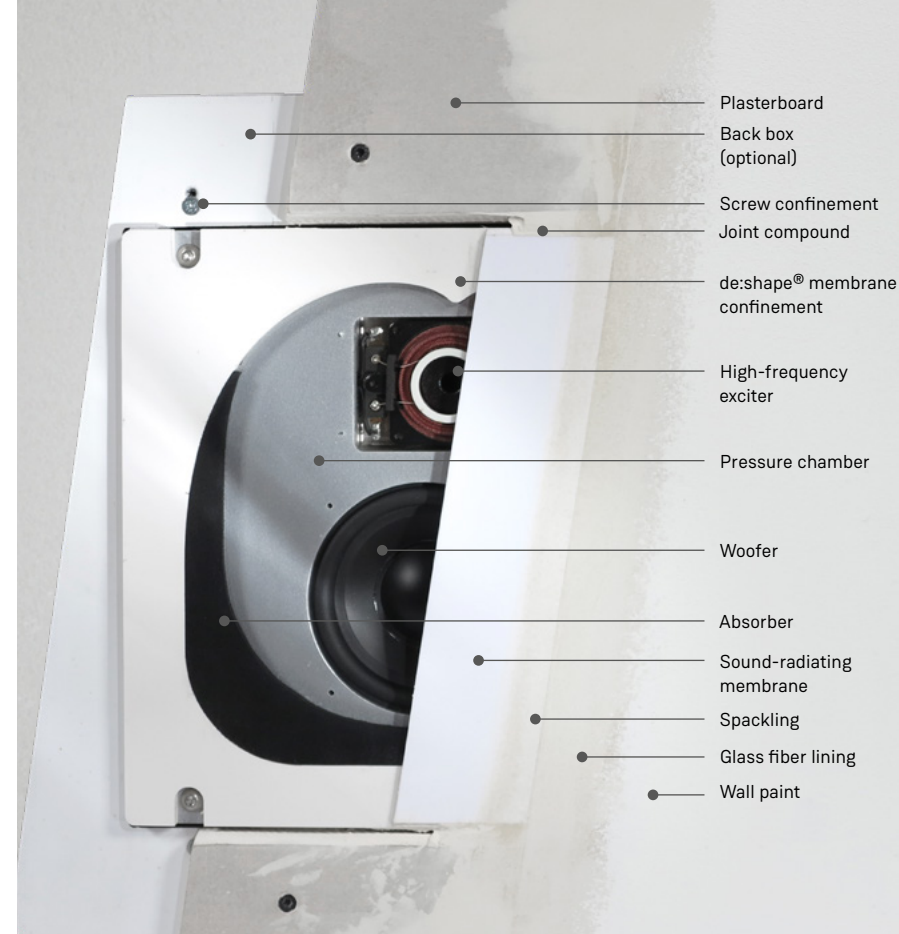

LOUDSPEAKER FOR INVISIBLE INTEGRATION INTO FURNITURE **DE Plan 200 inside**

The DE Plan 200 Inside is a special version of the 2-way flat transducer designed to be invisibly installed in furniture and wall panels. The speaker is glued into furniture facing and wall panels made of wood, MDF, or similar materials, and directly excites those surfaces. The surface is activated without an intermediate membrane, which makes this model extremely efficient and gives it an extensive, linear frequency range. It provides high-quality music and speech reproduction, making it equally suited to home audio, audiovisual rooms, and the hospitality sector. A wide dispersion angle of 180° means that sound can be distributed evenly throughout the room with just a few speakers.

The reproduction characteristics depend very much on the material in which the speakers are installed and the room's acoustics. We therefore recommend the lb system controller or the DSP power amplifiers, which can be adjusted to achieve the best sound pattern.

Operating principle: 2-way flat transducer | **Components:** 4" woofer + 1" dome tweeter | **Frequency range:** 70 Hz–20 kHz (built into MDF front panel with 3 mm wall thickness in front of the speaker) | **Impedance:** 8 Ω | **Power capacity:** 40 W RMS, 80 W program | **Sensitivity and SPL:** 79 dB (1 W/1 m), max. SPL 97 dB (depending on the material in which it is installed) | **Dispersion angle (H × V):** 180° | **Dimensions:** speaker: 300 × 240 × 72 mm | **Installed depth:** 72 mm | **Installation cutout:** cutout: 304 × 244 mm; remaining wall thickness in front of the speaker: 3 mm | **Weight:** 2.7 kg | **Connections:** screw-type terminals, pluggable | **Warranty:** 5 years





SURFACE-MOUNT SPEAKER WITH WIDE FREQUENCY RANGE **DA 180**

The DA 180 is an elegant surface-mounted speaker with balanced sound properties. Part of the installation series, it was designed as a component for surround systems, multi-room systems, AV installations, and voice announcements. The use of an electronically linearized 3" full range driver with high efficiency and high power capacity makes it equally suitable for reproduction of either speech or music.

With its flat, round design, it can be used as a wall-mounted or ceiling-mounted speaker. It works especially well as an addition to the DE series of speakers in areas where there is no wall paneling or suspended ceiling. We recommend using the extremely compact SUB 20 and SUB 20 A subwoofers to enhance the low frequency range.

Operating principle: 3" full range speaker with electronic equalization | **Components:** 3" full range driver | **Frequency range:** 140 Hz-20 kHz | **Impedance:** 8 Ω | **Power capacity:** 20 W RMS, 40 W program | **Sensitivity and SPL:** 85 dB (1 W/1 m), max. SPL 100 dB, 100 V version: max. SPL 95 dB | **Dispersion angle:** 100° conical (-6 dB) | **Dimensions:** d = 180 mm, H = 70 mm | **Installed depth:** 70 mm | **Weight:** 1.0 kg | **Connections:** screw-type terminals, pluggable, up to 2 x 4 mm² | **Warranty:** 5 years



LOUDSPEAKERS SURFACE-MOUNT SPEAKER



SURFACE-MOUNT SPEAKER WITH WIDE DISPERSION ANGLE **DA 250 (Q) Polar**

The DA 250 (Q) Polar is an elegant, 2-way surface-mounted speaker with Polar® technology for perfect hemispherical dispersion and high sound quality, even without additional subwoofers. Instead, an optimized cabinet design with two passive radiators ensures top-quality bass response. The dispersion angle of 180° guarantees uniform sound distribution. That means the auditory range can be covered with just a few speaker systems, even in large rooms.

These properties make the DA 250 (Q) suitable for high-quality home audio applications, museums, and the hospitality sector, but also for professional multimedia applications such as trade shows as well.

With its flat design, it can be used as a wall-mounted speaker or a ceiling-mounted speaker. The user can choose between round or square, and black or white, according to structural requirements. If there is a suspended ceiling in some areas, the DA 250 (Q) Polar can also be combined with the in-ceiling speakers DE 140 Polar and DE-X 140 Polar.

Operating principle: 2-way speaker with Polar technology | **Components:** 4" woofer + 0.75" dome tweeter + 2 × 4" passive radiators | **Frequency range:** 45 Hz-21 kHz | **Impedance:** 8 Ω | **Power capacity:** 30 W RMS, 60 W program | **Sensitivity and SPL:** 85 dB (1 W/1 m), max. SPL 103 dB, 100 V version: max. SPL 100 dB | **Dispersion angle:** 180° (-6 dB to 5 kHz) | **Speaker dimensions:** DA 250: d = 260 mm, H = 80 mm; DA 250 Q: 260 × 260 × 80 mm | **Weight:** 2.8 kg | **Fastening points:** concealed mounting bracket on back (included in delivery) | **Box:** aluminum, front: powder-coated fine-perforation grille | **Connections:** screw-type terminals, pluggable | **Warranty:** 5 years



HIGH-END SATELLITE SPEAKER WITH INTEGRATED HIGH-PASS FILTER S 2

The S 2 is a high-end satellite loudspeaker with a compact aluminum cabinet, wide frequency range, and precise, clear sound pattern. These properties are achieved by the use of a highly efficient 2.5" neodymium full range driver, bass-reflex tuning, and precise electronic frequency response linearization.

Thanks to the integrated high-pass filter, this speaker can be directly connected to amplifiers without an additional crossover. Moreover, with its very low cut-off frequency of 110 Hz, it can be combined with subwoofers without the stereo localization limitations that usually characterize subwoofer satellite systems whose crossover frequency is too high.

Two or more speakers can be combined into line arrays with a narrower vertical dispersion angle and longer throw. Connecting brackets with angles of 0°, 10°, and 20° are available for this purpose. The subwoofer to use with it is the SUB 20 A model, an active subwoofer that is especially suitable for surround systems with AV receivers.

Operating principle: full range speaker with electronic frequency response linearization and integrated high-pass filter, bass reflex | **Components:** 2.5" neodymium full range driver | **Frequency range:** 110 Hz-22 kHz | **Impedance:** 8 Ω | **Power capacity:** 20 W RMS, 40 W program | **Sensitivity and SPL:** 83 dB (1 W/1 m), max. SPL 97 dB | **Dispersion angle:** 120° | **Dimensions (W × H × D):** 80 × 100 × 105 mm | **Weight:** 0.6 kg / 100 V version: 0.8 kg | **Box:** aluminum, front: powder-coated fine-perforation grille | **Connections:** screw-type terminals, pluggable | **Warranty:** 5 years

ACTIVE HIGH-END-SATELLITE SPEAKER S 2 A

The S 2 A is an active, high-end satellite loudspeaker with a compact aluminum cabinet. It was designed with a highly efficient 2.5" neodymium full range driver, low bass-reflex tuning, and precise electronic frequency response linearization. This gives it an exceptionally extensive frequency range for its size, and a particularly precise, clear sound pattern.

With a very low cut-off frequency of 110 Hz, it can be perfectly combined with the SUB 20 A subwoofer. The S 2 A features an automatic switch-on function, which means it activates itself as soon as a signal is applied.

It can be installed with the wall brackets WH 10, WH 20, and WH 40, which differ in terms of their distance from the wall.

Operating principle: active satellite speaker with electronic frequency response linearization and automatic switch-on, bass reflex | **Components:** 2.5" neodymium full range driver | **Frequency range:** 110 Hz-22 kHz | **Amplifier output:** 20 W | **Sensitivity and SPL:** 83 dB (1 W/1 m), max. SPL 97 dB | **Dispersion angle:** 120° | **Dimensions (W × H × D):** 80 × 100 × 105 mm | **Weight:** 0.8 kg | **Box:** aluminum, front: powder-coated fine-perforation grille | **Connections:** stereo RCA input on back | **Power supply:** external power supply unit | **Input sensitivity:** -6 dBu | **Controls:** volume control on back | **Indicators:** LED "ON" | **Warranty:** 5 years



ACCESSORY
WH 10 Wall bracket
with short distance from wall

This bracket consists of a mounting plate and an adjustable bar, and is suitable for installation of the S 2 and S 2 A satellite speakers. The distance from the wall is 30 mm for this bracket.



ACCESSORY
WH 20 Wall bracket
with medium distance from wall

This bracket consists of a mounting plate and an adjustable bar, and is suitable for installation of the S 2 and S 2 A satellite speakers. The distance from the wall is 60 mm for this bracket.



ACTIVE STEREO SOUNDBAR WITH HIGHLY LINEAR FREQUENCY RESPONSE

SB-A 2.0

The active stereo soundbar SB-A 2.0 was designed for video conferences and high-quality sound reproduction in media rooms. It can be directly mounted on display screens and video walls.

The use of a digital signal processor (DSP) with multi-band limiters and the soundbar's linear frequency response give it a wide frequency range. It also reproduces speech very clearly and precisely, and is highly resistant to overdrive.

The soundbar is activated automatically: As soon as an audio signal is available, the integrated automatic switch-on function is activated. It switches back to standby after five minutes without a signal.

For mounting directly on a display screen, we recommend using the SB-VESA bracket. This allows mounting on display screens from 40" to 100". Alternatively, the soundbars can be fastened directly to a wall with the WH 80 wall bracket, or in a wall panel for flush mounting.



Operating principle: active stereo soundbar with class D amplifiers and DSP | **Components:** 2 x 2.5" full range drivers + 2 x 2.5" woofers + 4 x 2.5" passive radiators | **Frequency range:** 55 Hz-20 kHz | **Amplifier output:** 2 x 50 W | **Sensitivity:** max. 109 dB (1W/1m) | **Dispersion angle:** 120° | **Power supply:** external power supply unit 24 V DC | **Dimensions (W x H x D):** 960 x 80 x 48 mm | **Weight:** 5.0 kg | **Fastening points:** threaded inserts 4 x M6 on back | **Box:** aluminum, front: powder-coated fine-perforation grille | **Connections:** stereo RCA input, pluggable screw-type terminals for passive speakers and external power supply unit, 1.5 m input cable from 3.5 mm mini jack to RCA | **Line power:** 90-240 V AC | **Input sensitivity:** -6 dBU for full modulation, input impedance 10 kΩ | **Controls:** volume control, LED On/clip, on back | **Warranty:** 5 years



ACTIVE SOUNDBAR

SB-A Mini

The SB-A Mini is an active loudspeaker system for various areas of application. The soundbar was developed for precise reproduction of speech, and reproduces the audio signal with no distortion thanks to its linear frequency response. These properties are especially sought after in exhibitions, trade shows, and other communication systems.

The active speaker has an auto On/Off function which can be activated when required. As soon as an audio signal is available, the integrated amplifier is activated. The speaker switches back to standby after three minutes without a signal.

For installation, six mounting holes on the sides and back allow trim-less integration into furniture or display pedestals. Alternatively, the soundbar can be attached directly to the wall with the WH 80 wall bracket.

Operating principle: active mini soundbar | **Components:** 2.5" full range speaker | **Frequency range:** 190 Hz–19 kHz | **Amplifier output:** 20 W | **SPL:** max. 97 dB | **Dispersion angle:** 120° | **Dimensions (W × H × D):** 180 × 80 × 48 mm | **Weight:** 1.0 kg | **Fastening points:** threaded inserts 2 × M5 on back, 4 × M5 on side | **Box:** aluminum, front: powder-coated fine-perforation grille | **Connections:** 0.6 m input cable from 3.5 mm mini jack to RCA | **Input sensitivity:** -6 dBu for full modulation, input impedance 10 kΩ | **Controls:** volume control, switch for auto ON/steady ON, switchable high-pass filter, LED for power ON | **Warranty:** 5 years





5 INCH CUBE SPEAKER CUBE

The Ecler WiSpeak CUBE is an active 5" loudspeaker in cubic form. It connects wirelessly to the Core transmitter and works alone or together with up to 23 other connected devices to create a rich sound with strong bass response. In open space, the WiSpeak network can cover a range of 12 meters between the transmitter and the receiver. For mounting, either attach it to existing busbars or use the available accessories to install on a wall, ceiling, or shelf. It is available in either black or white.

Inputs: CH1 / CH2: digital, mono, RF wireless audio | **Outputs:** analog in mono, balanced with Euroblock port | **Power consumption:** 15 W | **Power output:** 32 W (8 Ω , 1% THD) | **Channels:** WiSpeak CH1 / CH2 | **Frequency range (-10 dB):** 70 Hz-20 kHz | **Remote control:** WiSpeak grip app | **Sound pressure (dB @ 1 m 1 W):** 83 dB | **Impedance:** 8 Ω | **Power supply:** 100-240 V AC; 50-60 Hz | **Structure:** aluminum grill, ABS enclosure | **Dimensions (without accessories):** 175 x 175 x 180 mm (W x D x H) | **Weight:** 2.1 kg



WIRELESS MUSIC TRANSMITTER CORE

The heart of this system, which is constructed from only a small number of components, is the Core transmitter unit. At the touch of a button, it establishes a permanent wireless connection with the Tube and Cube loudspeakers. Up to 24 receiver units can be controlled from one transmitter. With a range to the receiver of 12 meters in open space, the transmitter can cover a total distance of 24 meters. If longer distances need to be spanned or the signal has to be transmitted through walls, additional transmitters can be connected by cables to existing receivers. These additional core transmitters take the signal from the loudspeaker they are connected to and pass it on to a further 24 devices, with virtually zero latency. This allows sound to be transmitted across even quite long distances without interruption.

Two separate channels are available for combining the two receiver units, Tube and Cube, within one transmitter. This allows both models to be adjusted according to their specific sound characteristics.

Computers, tablets, and other audio players can be used as the audio sources, via cable or Bluetooth. The Core transmitter constantly monitors the stable wireless connection to the speakers, and changes the channel automatically if the frequency is disrupted. For individual control, the user can choose between three input channels and set the desired volume, either on the base station or via the associated app. The feature-rich app also allows customized sound tuning, and works on both iOS and Android devices.

Inputs: IN1: balanced, stereo, Euroblock; IN2: unbalanced, stereo, RCA BT: Bluetooth wireless | **Outputs:** CH 1&2: digital, mono, RF wireless audio / AUX OUT: analog, mono, balanced, Euroblock | **Power consumption:** 0.5 A @ 24 V | **Channels:** WiSpeak CH1 / CH2 | **Frequency range:** IN1: 10 Hz–20 kHz (-1 dB), IN2: 10 Hz–20 kHz (-1 dB), BT: 10 Hz–20 kHz (-1 dB) | **Output resolution:** 24 bit AD/DA conversion | **Bluetooth®:** Bluetooth 5.0, class 1, range 25 m (ideal conditions) | **Latency:** < 6 ms | **Remote control:** WiSpeak grip app / WPa-VOL (optional) | **Control options:** front panel, WiSpeak grip, WPa-VOL remote control | **Communication standard:** RF wireless audio | **Features:** MUTE, remote control connection | **Tone control:** BASS: 100 Hz, ± 10 dB, MID: 1.2 kHz, ± 10 dB, TREBLE: 10 kHz, ± 10 dB | **Input power:** 100–240 AC; 50–60 Hz | **Dimensions (without accessories):** 225 × 120 × 40 mm (W × H × D) | **Weight:** 0.8 kg



REMOTE CONTROL APP RePLAYER

The WiSpeak grip app can be used to install and configure the entire wireless audio system. This includes separate tone and volume settings for every connected speaker. The control interface is highly user-friendly, which makes it easy to work with on a daily basis. All the functions are clearly organized on a single screen, with no hidden control panels, so the user does not waste time searching for settings. The app is available for both Android and iOS devices.



ACTIVE LOUDSPEAKER KIT eMOTUS5P

The eMOTUS5P is a loudspeaker kit with one active speaker and one passive speaker. The relevant audio signal is supplied to them via two line inputs. The user can choose between balanced and unbalanced inputs to connect not only the widely used jack and RCA plugs but also Phoenix connectors as well. This ensures a multitude of possible multimedia applications. In addition, the balanced inputs can be used to ensure interference-free transmission even over long distances. Common areas of application include the education sector, conferences and meetings, and retail stores.

The delivery includes a wall bracket and a steel cable for secure mounting. The speakers are available in white.

Power output: 2 × 25 W RMS | **Impedance:** 8 Ω | **Frequency response (-10 dB):** 85 Hz–20 kHz | **Power supply:** 115 / 230 V AC (selectable) | **Structure:** aluminum grill, ABS enclosure | **Dimensions (without accessories):** 173 × 185 × 180 mm (W × D × H) | **Weight:** 4.2 kg





OUTDOOR LOUDSPEAKER SYSTEM eMOTUS50D

The eMOTUS50D cabinet was developed for outdoor installation in gardens, parks, urban spaces, theme parks, and sports complexes. This compact and professional speaker is easy to use, and has full IP65 protection against dust and water jets from any direction. The ports are located behind a rubber cover.

A special feature of the speaker is that it allows either high or low impedance operation, thanks to the power selector switch. The nominal impedance of 8 ohms ensures lossless transmission of audio signals over short distances, while the 100 V technology allows multiple speakers to be connected to a single system.

The speakers are available in white and black, and come with a wall bracket and a steel security cable.

Power output: 40 WRMS / 80 W peak | **Impedance:** 8 Ω |
Power selector switch: 30 W / 15 W / 7.5 W / 3.75 W @ 100 V & 8 Ω;
15 W / 7.5 W / 3.75 W / 1.8 W @ 70 V & 8 Ω | **Frequency response**
(-10dB): 75 Hz–20 kHz | **Structure:** aluminum grill, ABS enclosure |
Dimensions (without accessories): 173 × 181 × 180 mm (W × D × H) |
Weight: 2.2 / 2.5 kg (with/without wall bracket)





SPHERICAL PENDANT LOUDSPEAKER eUC106

With its attractive spherical shape, the eUC106 is especially suitable for use in bars, restaurants, shopping malls, and retail premises. In addition, its dispersion pattern of 110 degrees makes it ideal for sound reinforcement in particularly high rooms.

An EASE file for Windows is available, for the creation of efficient and precise sound reinforcement solutions. Using a 6.5" woofer and a 1" tweeter in a coaxial arrangement, the pendant speaker achieves excellent sound characteristics for high-quality sound reinforcement and music reproduction.

The power selector switch can be used to choose between high and low impedance operation. Over short distances, exceptionally lossless transmission of the audio signal can be ensured. It is also possible to connect multiple speakers with just one line.

The speaker is available in white and black.

Power output: 40 W RMS / 80 W peak | **Impedance:** 8 Ω | **Power selector switch:** 32 W / 16 W / 8 W / 4 W (100 V) & 8 Ω; 16 W / 8 W / 4 W / 2 W (70 V) & 8 Ω | **Frequency response (-6 dB):** 100 Hz–20 kHz | **Dimensions (without accessories):** Ø 270 × 215 (H) | **Weight:** 3 kg





WALL MOUNT SPEAKER

eAMBIT103

The eAMBIT103 is an ultracompact two-way cabinet speaker with a discreet, neutral design. It is suitable for both foreground and background sound reinforcement, making it just as appropriate for shopping malls, retail premises, and cafes, as it is for meeting and conference rooms.

It consists of a 3.5" woofer and a 0.5" tweeter in a coaxial arrangement, achieving excellent sound characteristics for high-quality sound reinforcement and music reproduction.

The power selector switch can be used to choose between high and low impedance operation. With short line lengths, exceptionally lossless transmission of the audio signal can be ensured. It is also possible to connect multiple speakers with just one line.

Thanks to IP54 protection, this speaker can also be used in outdoor areas. A special surface treatment protects the enclosure from yellowing in direct sunlight.

The speaker is available in white and black. It comes with a wall bracket, steel security cable, and also screws and a wrench for quick installation.

Power output: 25 W RMS / 50 W peak | **Impedance:** 8 Ω | **Power selector switch:** 2.5 W / 5 W / 7.5 W / 15 W & 8 Ω | **Frequency response (-3 dB):** 150 Hz-20 kHz | **Sound pressure (dB @ 1 m 1 W):** 87 dB | **Dimensions (without accessories):** 120 × 120 × 117 mm (W × H × D) | **Weight:** 1.275 kg





MEDIA PLAYERS

—
SOLUTIONS
TO MATCH
EVERY NEED

Molitor offers a range of different media players for continuous operation of professional audio and video installations. These were developed in close cooperation with our media technology department and perfected with regard to their practical experience.

For us, high product quality, durability, practicality, intuitive programming, and high connectivity are the most important requirements for our players.

Every project needs its own specific solution and therefore we offer a selection that meets all challenges, from simple, low-cost media players to high-resolution devices for professional requirements. The media players AP01, MP01, and MP024K in our red product line come standard with headphone amplifiers, and impress with their high connectivity and comprehensive features. The media players from the black series offer outstanding quality at exceptionally reasonable prices.

AUDIO PLAYER

AP 01

The AP 01 is a versatile, interactive audio player. As a stand-alone device, it can be put to use immediately, and will impress with its high-quality construction and excellent sound quality. The AP 01 audio player was specially designed for use in exhibitions, trade show and sales installations, information pillars, and for continuous operation.

Handsets, pushbuttons, and sensors can be connected to the player effortlessly with the easy-to-use Phoenix connector. In addition to an included standard playlist, freely configurable playlists allow you to play even quite complex sequences. Nine freely assignable inputs let you integrate pushbuttons and sensors into your programming via dry contacts, for sophisticated applications. The audio files can be stored on either an SDHC memory card or a USB flash drive. An integrated amplifier allows the connection of up to two handsets or headphones. In addition, external amplifiers and active speakers can be connected via the line output.

Power supply: 12 V DC | **Supported storage devices:** SDHC memory card, USB drive, each up to 64 GB | **Formatting:** FAT, FAT32, NTFS | **Outputs:** phone output (3.5 mm stereo jack plug), phone output (stereo Phoenix connector), audio line out (3.5 mm stereo jack plug) | **Inputs:** 10-pin IN port (Phoenix connector), 2-pin switching contact for handsets (Phoenix connector) | **Supported audio formats:** MP3 (up to 320 kbps), WAV (up to 3 Mbps) | **Amplifier:** integrated amplifier for up to two handsets or headphones, max. power 80 mW | **Playlist:** freely configurable



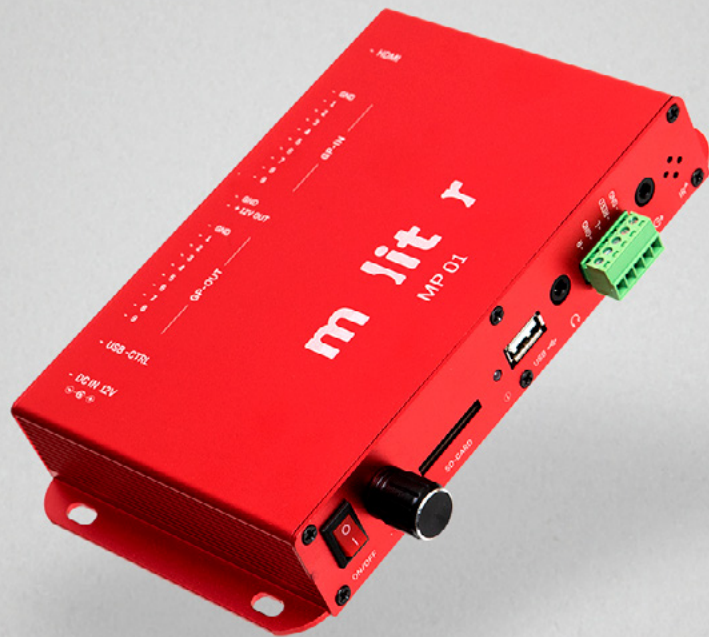

MEDIA PLAYER MP 01

MEDIA PLAYER

MP 01

The MP 01 media player was designed by molitor for continuously running interactive video installations in exhibitions, trade show and sales installations, and for information pillars. Handsets and headphones can be connected to the player very easily with a Phoenix connector, as can buttons, sensors, and their internal lighting. Projectors and full HD display screens can be connected to the standard HDMI port.

Configurable playlists and included standard playlists allow you to play even quite complex sequences with ease. Nine freely assignable inputs let you integrate pushbuttons and sensors into your programming via dry contacts, for sophisticated applications. Nine switching outputs, operating independently of one another, can be freely configured as well, for functions such as button lighting. The audio and video files are stored on an SDHC memory card or a USB flash drive.

An integrated amplifier allows the connection of up to two handsets or headphones. In addition, external amplifiers and active speakers can be connected via the line output. If required, the switching outputs can be expanded: An optional external board is available that permits the use of relays, motors, etc. A remote control for configuration comes included with the player.

Power supply: 12 V DC | **Supported storage devices:** SDHC memory card, USB drive, each up to 64 GB | **Formatting:** FAT, FAT32, NTFS | **Outputs:** phone output (3.5 mm stereo jack plug), phone output (stereo Phoenix connector), audio line out (3.5 mm stereo jack plug) HDMI output, 10-pin OUT port (Phoenix connector), 12V output (Phoenix connector) | **Inputs:** 10-pin IN port (Phoenix connector), 2-pin switching contact for handsets (Phoenix connector) | **Video formats:** MP4, MOV, and others (up to 1080p) | **Audio formats:** MP3, WAV | **Amplifier:** integrated amplifier for up to two headphones or handsets | **Power:** max. 80 mW | **Playlist:** freely configurable | **Accessories:** 12 V power supply unit, 100-240 V AC; remote control; Phoenix connectors 2-pin, 5-pin, and 10-pin

MEDIA PLAYER MP 02 4K

This Ultra HD media player boasts brilliant 4K HDR video output, a multitude of control options, and the capacity to synchronize multiple players during operation. The MP 02 4K is designed for maintenance-free continuous operation and the integration of interactive video installations. The player's range of possible applications is extremely broad, encompassing exhibitions, video art, trade shows, and sales. To create multi-screen projections or complex video walls, the player permits frame synchronization of up to 255 media players in up to ten groups. You can easily drag the content for your projection onto the storage medium or interchange it. Just set up a network connection, and then use the web browser to perform the required action with the user-friendly drag-and-drop function. Previously selected settings are retained, and there is no need for additional software editing. Timer-controlled calendar playlists are created using the built-in calendar function.

A highlight of the MP 02 4K is its versatile connectivity: For control, there are USB ports and also nine GP inputs (on a Phoenix connector), which can be connected to a touch screen, pushbuttons, RFID, or motion detectors. The additional 5-pin handset port allows automatic starting and stopping of the player by handsets with reed contacts. The integrated amplifier can be used to connect up to two handsets or headphones. In addition, external amplifiers and active speakers can be connected via the line output..

Power supply: 12 V DC | **Supported storage devices:** microSDXC / SDHC memory cards, USB flash drive (up to USB 3.0), each with 64 GB | **Outputs:** phone output (3.5 mm stereo jack plug), phone output (stereo Phoenix connector), audio line out (3.5 mm stereo jack plug) HDMI output, 12 V output (Phoenix connector) | **Inputs:** 10-pin IN port (Phoenix connector), 2-pin switching contact for handsets (Phoenix connector), RJ45 1000 Mbps network port (for control functions, synchronization, and content updates) | **Video formats:** MP4, MOV, and others up to 3840 × 2160 at 60p, max. bit rate 40 Mbps | **Audio formats:** MP3, WAV | Amplifier: integrated amplifier for up to two headphones or handsets | **Power:** max. 80 mW | Playlist: freely configurable





MEDIA PLAYER 4K LIGHT

MEDIA PLAYER

4K Light

This Ultra HD media player with its brilliant 4K HDR output is very simple to set up with its plug-and-play functionality. Video, image, and HTML5 content is displayed automatically as soon as the player is connected to the power source.

The 4K Light Player is the perfect solution for video installations where content needs to be played easily and directly. It can be controlled via a USB port, and permits frame synchronization with other players of the same type via a network connection. With its small size, it can be installed very unobtrusively. Separate digital and analog audio outputs enable the connection of audio amplifiers, headphones, and surround sound decoders. This makes the 4K Light Player the ideal player in public spaces: whether in museums, trade shows, or shopping malls, it offers a cost-effective and easy-to-use alternative to conventional players.

Power supply: 5 VDC | **Supported storage devices:** SDHC memory card, USB drive, each up to 64 GB | **Formatting:** FAT, FAT32, NTFS | **Outputs:** HDMI 2.0, analog video and stereo audio via 3.5 mm stereo jack plug (TRRS) | **Inputs:** Ethernet (RJ45), USB 3.0, USB 2.0 | **Video formats:** MP4, MOV, WMV, MKV, AVI | **Audio formats:** MP3, WAV, AAC | **Accessories:** 5 V power supply unit, 100–240 VAC; wireless LAN antenna

MEDIA PLAYER

movebox®

The great-value movebox®, the HD 1080P-1 media player, is a fully featured HD player. The device enables you to display video clips, music files, and digital images in HD quality (1080p).

The movebox® can be connected to any standard LCD monitor, TV monitor, or video projector via HDMI or composite video outputs. The separate analog audio output can be used to connect an audio or headphone amplifier. As soon as the device is plugged into the power source, it automatically plays the audio or video content on the memory card (or USB drive) in a loop, or as a slideshow in the case of images. The accompanying remote control can be used for detailed operation and onscreen configuration.

Enclosure: aluminum | **Video system:** PAL/NTSC | **Video files:** MPEG1, MPEG2, MPEG4 (XVID), DIVX, H264, H263, AVI, WMV9/VC1, RMVB, MKV, VOB, PMP, TS/TP, MOV, MP4, etc. | **Image files:** JPEG, BMP, GIF, PNG, TIFF, RAW | **Audio files:** MP3, WAV, WMA, OGG, AAC, FLAC, ASF | **Video outputs:** HDMI 480p, 720p, 1080i, 1080p (50/60 Hz), composite PAL/NTSC (jack plug) | **Audio output:** stereo, jack plug | **USB port:** version 2.0 Host | **Storage medium:** SDHC/MMC (max. 32 GB) HDD 2 TB | **Input voltage:** 5 V DC | **Dimensions:** 80 × 58 × 16 mm (W × D × H) | **Included in delivery:** remote control, 100–240 V AC power supply unit, audio/video cable, 5 V DC USB cable, and operating manual



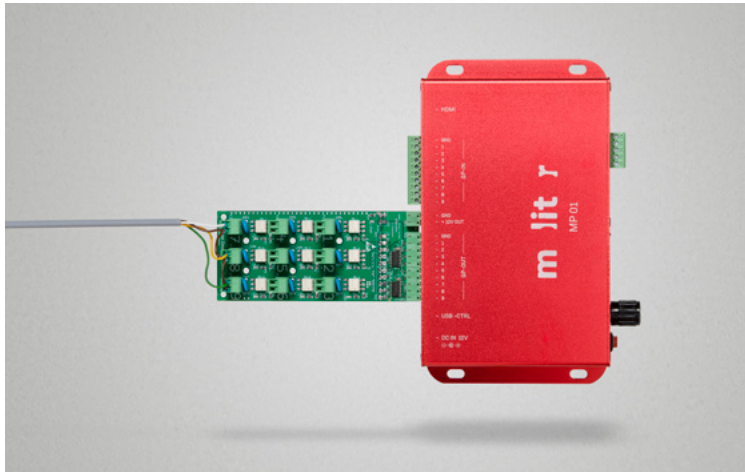

ACCESSORY

Expansion card for the MP01

This non-wearing external card expands the range of possible applications of the molitor MP01 media player. When plugged into the player, it is automatically supplied with operating voltage and switching signals. The nine independent switching outputs are controlled via the player's GP-Out. The programming of the playlist is as usual. The individual switching outputs can be used for dry switching of voltages of up to 30V and currents of up to 3A, so you can control relatively large loads such as motors, relays, and low-voltage lighting.

Power supply: 12VDC | **Max. current consumption:** 550 mA | **Maximum voltage switched per switching output:** 30 V AC or DC | **Maximum current switched per switching output:** 3 A | **Outputs:** 9 × dry switching outputs (2-pin Phoenix connectors) | **Inputs:** 10-pin port for switching inputs (Phoenix connector), 2-pin port for power supply (Phoenix connector)

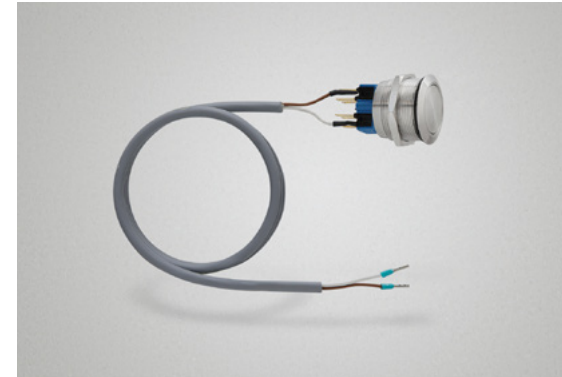

ACCESSORY

Pushbutton and Wiring

We also supply robust stainless steel pushbuttons separately, for interactive media stations. We would be happy to assemble cabling in customized lengths and designs, in consultation with you, for you to install in your system, such as between pushbuttons and players.

		AP 01	movebox®	MP 01	4K Light	MP 02 4K
Features	Auto play with connected power supply	○	○	○	○	○
	Reed contact*	○		○		○
	Integrated headphone amplifier	○		○		○
	Video synchronization					○
	Touch screen control					○
	Network capability				○	○
	HTML5				○	○

Video						
	Analogue video		○		○	○
	Full HD 1080 p60		○	○	○	○
	Ultra HD 4K @60 p				○	○

File formats		Audio					
	MP3	○	○	○	○	○	
	WAV	○	○	○	○	○	
	AAC		○		○	○	
	FLAC		○		○	○	
Video							
		MOV		○	○	○	○
		MP4		○	○	○	○
		MKV		○	○	○	○
		MPG/MPEG		○	○	○	○
	WEBM					○	
Image							
		JPG		○	○	○	○
		PNG		○	○	○	○
		BMP		○	○	○	○
		GIF		○		○	○
	TIF		○		○		

		AP 01	movebox®	MP 01	4K Light	MP 02 4K
Connections	Phone output (3.5 mm stereo jack plug) volume adjustable	○		○		○
	Phone output (stereo Phoenix connector) volume adjustable	○		○		○
	Audio line out (3.5 mm stereo jack plug)	○		○		○
	SPDIF – Digital Audio (TOSLINK)				○	
	9 × universal switching outputs	○		○		○
	9 × universal switching outputs			○		
	AV output		○		○	○
	HDMI output		○	○	○	○
	Ethernet				○	○
	SD Card	○	○	○	Micro SD	○
	UBS sockets	1 × contents	1 × content	1 × content	1 × USB 3.0 1 × USB 2.0 (external devices)	3 × USB 3.0 (content and external devices)

Miscellaneous		AP 01	movebox®	MP 01	4K Light	MP 02 4K
Dimensions (B × T × H)		160 × 145 × 30 mm	80 × 58 × 16 mm	185 × 160 × 30 mm	115 × 105 × 20 mm	190 × 180 × 35 mm
Weight		290 g	82 g	370 g	225 g	490 g
Power supply		12 V/2 A	5 V/2 A	12 V/2 A	5 V/2 A	12 V/2 A
Power consumption		3 W	2 W	3 W	5 W	12 W
Operating temperature range		0–40 °C	0–40 °C	0–40 °C	–10–40 °C	0–40 °C

* Additional input to connect to a reed contact and built-in programming to start and stop playback based on reed status.

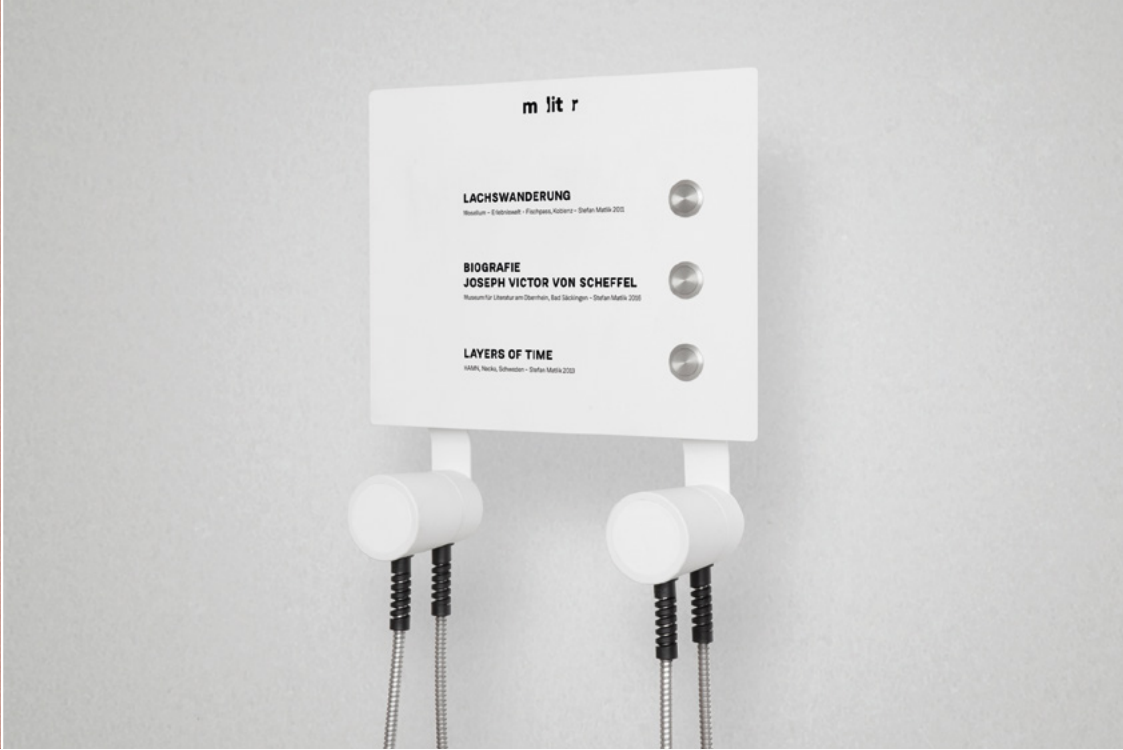

MEDIA STATIONS

— COMPLETE CUSTOMIZED PACKAGES

In many of our projects, we have developed specially made, customer-specific products that integrate a number of different media systems. We do this by combining individual components and high-quality technology to create a simple and elegant design focused on functionality and durability. For the components, we prefer to use products already available in our own range. The AIO station, for example, combines our AP01 audio player with our trusted headphones and handsets, to form a self-contained functional unit.

As plug and play packages, our media stations can be put into service immediately without any additional adjustment or prior technical knowledge. At the same time, you can configure the content and the user interface to suit your specific needs.

Because we manufacture these standard products in small batches in our own workshop, we can also supply systems customized to your requirements.



MEDIA STATIONS MUSE MULTIMEDIA COCOON CHAIR



MULTIMEDIA COCOON CHAIR **MUSE**

The multimedia cocoon chair MUSE creates a space for relaxation, concentration and retreat, while also inviting visitors to sit back and listen to audio and music with its integrated loudspeakers and media technology.

Its basic function is that of a comfortable cocoon chair, which achieves a high degree of separation from the outside world without being completely cut off; an open front ensures eye contact with surrounding people and participation in events going on outside the chair are still maintained.

The handcrafted cushions provide a high level of seating comfort. The fabric covers can also be easily removed and cleaned, allowing the chair to be used even in places with high visitor numbers. When selecting the fabric, attention was paid to low susceptibility to dirt, high resistance to abrasion and colour



fastness. Thanks to the wide choice of colours for the interior and exterior covers, our MUSE chair can be individually designed to fit in with its surroundings. The supporting base frame is made of curved flat steel and is available either powder-coated or chrome-plated as standard.

The technology inside the chair is optimally set up: Hidden integrated speakers are arranged in a “stereo triangle” to provide a balanced listening experience, while acoustic insulation elements ensure optimal audio quality inside the chair and mean that very little sound penetrates to the outside. An LED panel in the ceiling area, meanwhile, provides atmospheric lighting.

All the media technology is controlled by a swivel-mounted touchscreen, the interface and content of which can be designed and configured as desired.

The versatile cocoon chair is available in a number of different versions and is manufactured according to individual needs and wishes – which applies to both the colour of the fabrics and the technical equipment.





For example, the entire chair can be upholstered with or without any additional technology. Optional extras include a circular panel in the ceiling area, which provides atmospheric lighting that is synchronised with the audio playback, as well as bass speakers installed under the seat for more structure-borne sound.

Our MUSE chair is made to order, allowing customers to pick and choose from a range of options to design a solution that is tailor-made to their needs.

Chair dimensions without monitor: 1058 × 1021 × 1724 mm (D × W × H) | **Control monitor (display):** 10" | **Weight:** approx. 120 kg





MUSE FABRIC COVER COLOUR CHART

Exterior fabric PONTI



Interior fabric GAVI

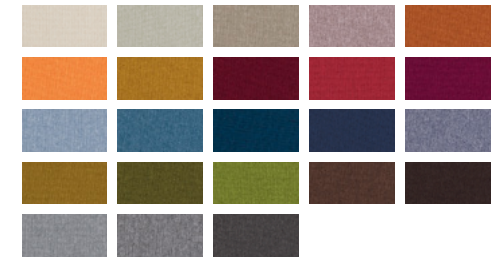

Exterior fabric: Manufacturer: Delius; flammability: DIN 4102/B1; abrasion resistance (Martindale): approx. 30,000 cycles | **Interior fabric:** Manufacturer: Delius; flammability: DIN 4102/B1; abrasion resistance (Martindale): approx. 80,000 cycles

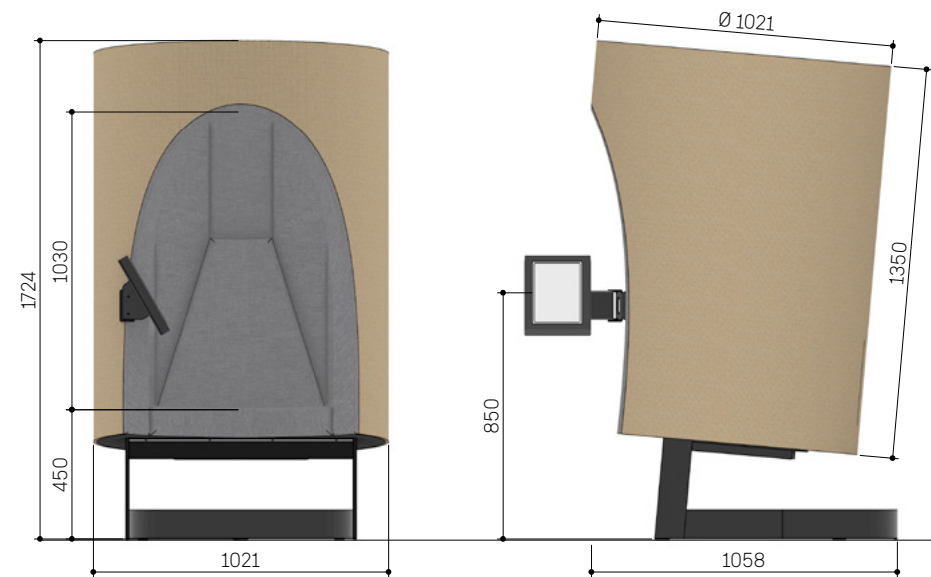

AUDIO STATION AIO

Our complete audio station AIO combines high functionality with easy installation, sturdiness, and versatility. The heart of the station is our AP 01 audio player with its integrated headphone amplifier. The audio tracks and the programming are stored on an SD card, so you can start the player directly without any further configuration.

Up to two of our DIO or MIO headphones or VIA or USO handsets can be used with the station. The integrated holder provides a safe storage place for the headsets, keeping them always ready to hand.

The resilient housing made of powder-coated stainless steel accommodates up to four buttons for selecting audio tracks. The control panel provides ample space for labeling the buttons. Expansions beyond four buttons are possible as a custom option. Similarly, the powder coating of the AIO complete station can be customized in all RAL Classic colors upon request.

An electrical supply line is all that is required for operation. Setup and maintenance therefore couldn't be simpler. Needless to say, we also produce the labeling and artwork, using laminated film according to your specific requirements. Thanks to this complete package, we can guarantee the immediate use of the product.



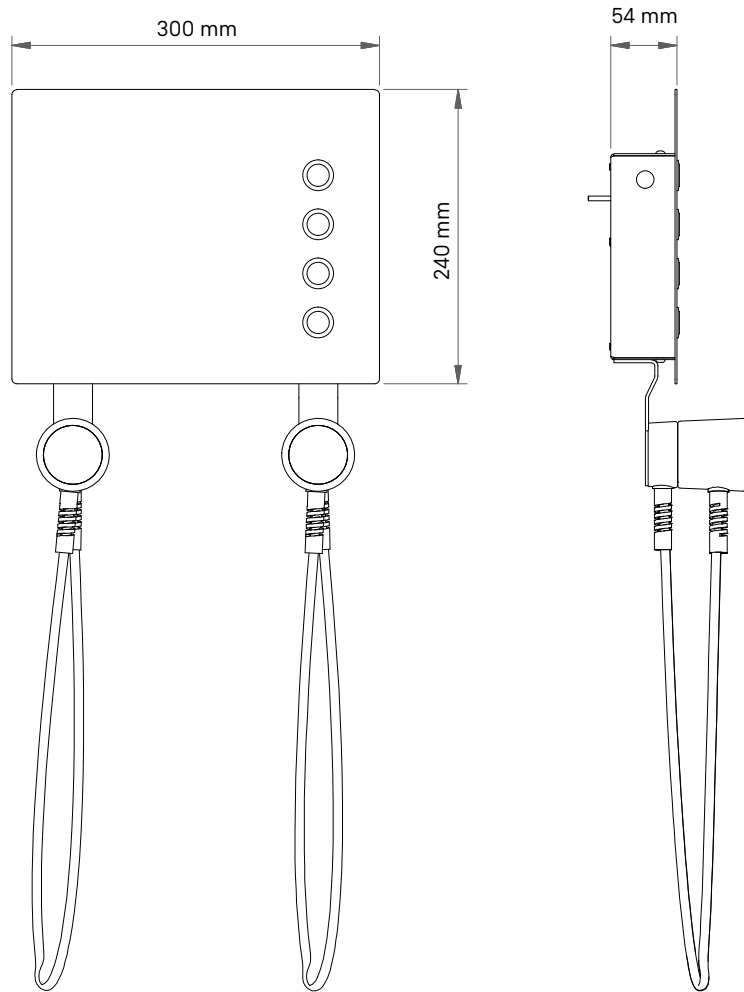

Dimensions: 30 × 24 × 5.4 cm | **Power supply:** 12 VDC | **Supported storage devices:** SDHC memory card, USB drive, each up to 64 GB | **Formatting:** FAT, FAT32, NTFS | **Outputs:** phone output (3.5 mm stereo jack plug), phone output (stereo Phoenix connector), audio line out (3.5 mm stereo jack plug) | **Inputs:** 10-pin I/O port, dry contacts (Phoenix connector), 2-pin switching contact for handsets (Phoenix connector) | **Supported audio formats:** MP3 (up to 320 kbps), WAV (up to 3 Mbps) | **Amplifier:** integrated amplifier for up to two handsets or headphones, max. power 80 mW | **Playlist:** freely configurable

MEDIA STATIONS AIO AUDIO STATION

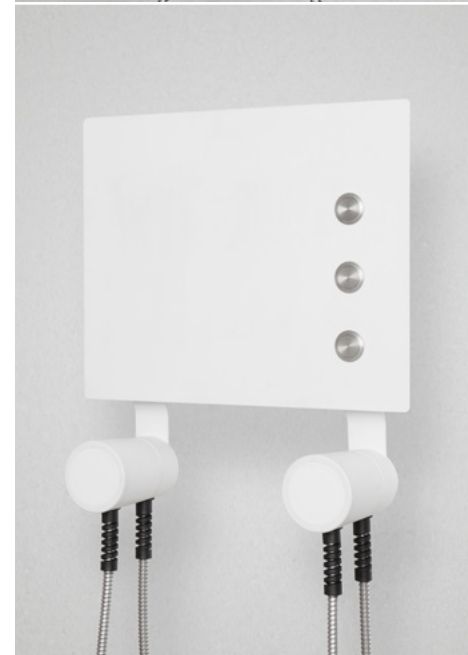

**GALLERY —
EXAMPLE INSTALLATIONS**





MONITORS

WELL ROUNDED DESIGN

Some situations call for a special monitor. The round screens we offer create a special atmosphere, with an unconventional shape that catches the eye. For an attractive design effect,

they can be embedded flush into a surface. Areas of application range from restaurants and museums to showrooms and trade shows.

ROUND LCD VIDEO SCREEN

23.6 inch

This circular 23.6 inch screen was developed for continuous playback of full-HD video clips. Content can be played back conveniently from a USB drive, SD card, or external devices. The available ports also allow the connection of motion detectors, which can activate the display directly. It is also possible to synchronize the videos with music.

With its streamlined metal housing, the screen is suitable not only for use as a monitor, but also as a tool for the presentation of static images. Areas of application include specialty stores, supermarkets, restaurants, storefront displays, museums, and banks.

Power supply: 24 V DC, 3 A | **Maximum image size:** 23.6" (dia. 604.38 mm) | **Resolution:** 848 × 848 px | **Field of view:** 178° horizontal / 178° vertical | **Brightness:** 700 cd/m² | **Video files:** MP4 / H264 | **Video resolution:** 1920 × 1080 px | **Ports:** HDMI (2 ×), USB, microSDHC | **Outputs:** 3.5 mm audio mini jack | **Input voltage:** 100–240 VAC | **Operation:** remote control unit | **VESA mount:** 400 × 200 mm, M6 | **Dimensions:** D 667 × 61.3 mm (W/D) | **Accessories:** remote control, EU power cable





ROUND LCD VIDEO SCREEN

5 inch

This round 5 inch LCD video screen with integrated media player is designed to play back video clips in HD. When supplied with power, it automatically starts endless playback of the clips. The files required can be loaded and saved onto the player by convenient drag and drop via a cable or from the USB port on the player. They can then be played back directly, and synchronized with other devices.

With its streamlined metal housing, the screen is suitable not only for use as a monitor, but also as a tool for the presentation of static images. Areas of application include specialty stores, supermarkets, restaurants, storefront displays, museums, and banks.

Image size: 5" (dia. 127 mm) | **Resolution:** 1080 × 1080 px | **Field of view:** 178° horizontal / 178° vertical | **Brightness:** 380 cd/m² | **Video files:** MP4 | **Video resolution:** 1080 × 1080 px | **Ports:** 3 × Micro USB | **Internal memory:** 4 GB | **Input voltage:** 5 VDC | **Loudspeakers:** 2 × 2 W | **Operation:** IR remote control | **VESA mount:** 50 × 50 mm, M4 | **Dimensions:** D 152 × 17.5 mm (W/D) | **Accessories:** remote control, USB cable, 100-240 VAC power supply unit



LEANDER

THE ELEGANT BARRIER AND GUIDANCE SYSTEM

LEANDER is your versatile, customizable, and aesthetically appealing guide. It is used wherever there is a need to maintain distance, to inform, and to be able to adapt quickly to changing circumstances.

Numerous add-on elements have been newly added to the LEANDER barrier and guidance

system, in response to the current requirements for safety and occupational health. These include a holder for hand sanitizer dispensers, signage in various formats, exhibit and artwork labeling, monitor holders, and flyer stands.

As a full service provider, we also develop customized equipment at your request.

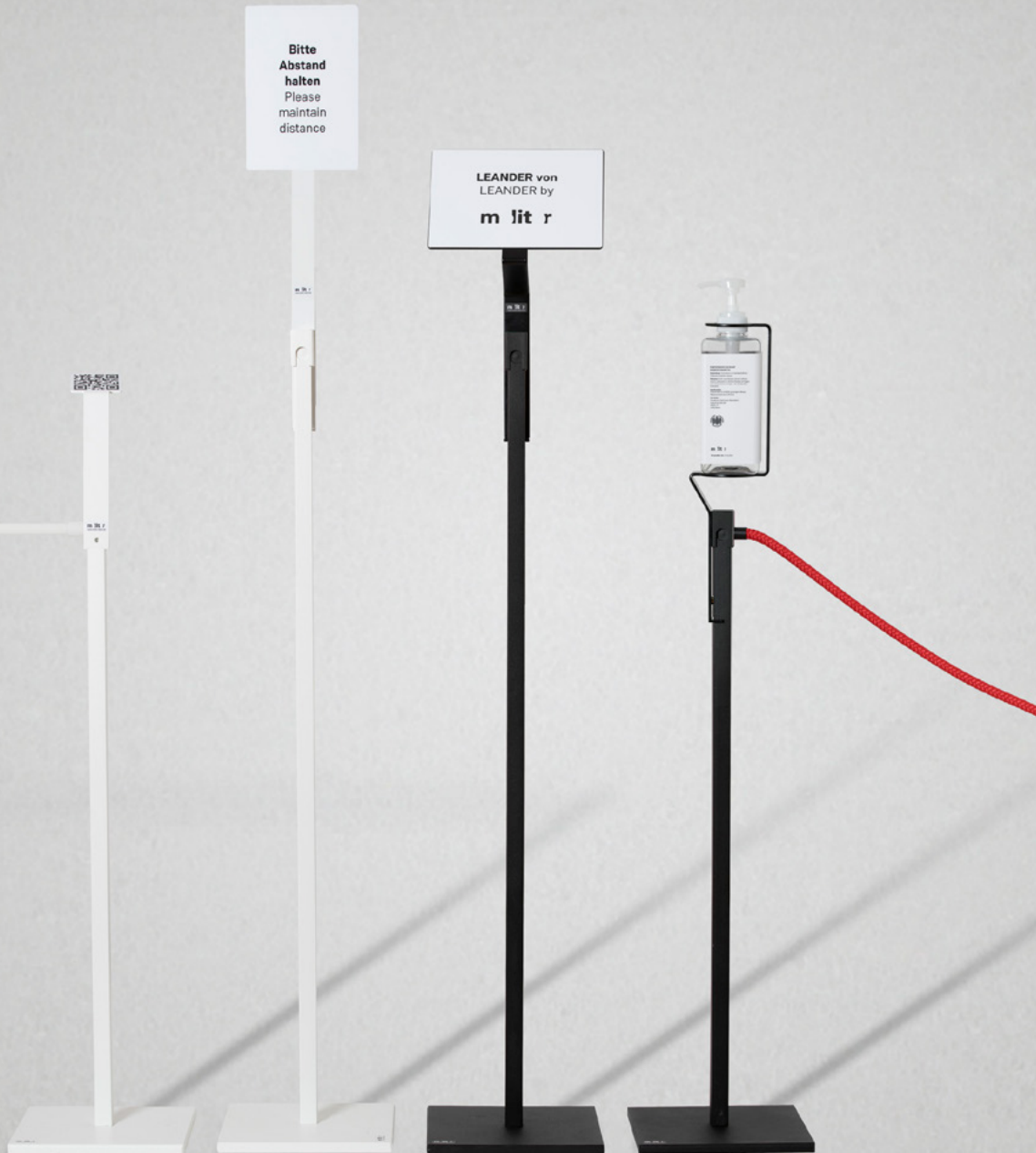

Whether as a temporary cordon, a guidance system, or a permanent boundary marker in your facility, LEANDER is extremely versatile thanks to its structured system. It shows the way, providing maximum functionality in a simple design.

The LEANDER system consists of a stand that comes in three heights, and more than 25 attachments. The classic straight-line design is continued throughout all elements. The simple, uniform, and functional design allows you to freely combine stands with different attachments in one installation.

Up to four elements can be attached to one stand. For example, you can affix ropes or rods to two sides and then also attach both a sanitizer bottle holder and a sign. With its large variety of elements and combination options, LEANDER can perform a wide range of functions.

No tools are required for assembly, so the system is suitable for temporary installation, can be disassembled quickly and easily after use, and can be stored in the tightest of spaces.

All the add-on elements are installed without the need for tools. Up to four elements can dock onto a LEANDER stand, allowing the stands to be set up either in a row and around corners, while optionally providing space for two more attachments.

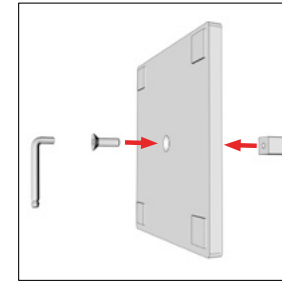

1 The stand is firmly mounted on its base plate using the supplied Allen screw and wrench. A recess prevents the stand's pole from twisting.

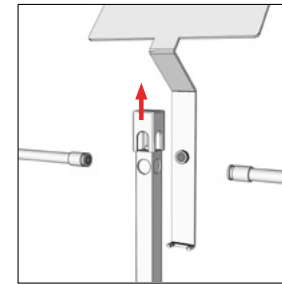

2 In the second step, the cap of the stand is pulled up. The desired attachments are brought into position.

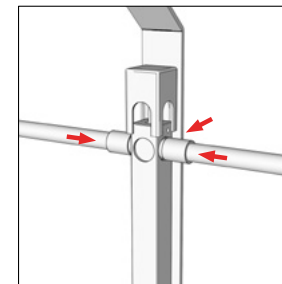

3 A magnetic retaining pin is used to position each attachment precisely in the recess on the stand. Another magnet and two retaining clips further secure the element.

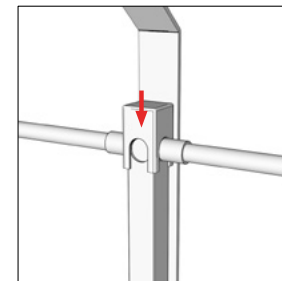

4 Once the add-on elements are positioned in the recess on the stand, the cap is pushed down. It fixes itself into the groove around the securing pin for positive locking.



LEANDER Stand

The LEANDER stand comes with a base plate, end cap, mounting screw, and Allen wrench. It is available in three different heights and powder-coated in Black or White. Other RAL colors are available as customized options. The add-on elements, such as a rope or rod, are held to the stand by a magnet integrated in their end sleeves, and by positive locking with the end cap. All add-on elements are mounted and secured without the use of tools.

Colors: ■ Black □ White | **Heights:** 50 / 70 / 90 cm



Do you have your own specific requirements? As a full service provider, molitor creates customized solutions too, as seen here with a continuous mounting rail instead of the base plate at the Graf Luxburg Museum in Aschach Palace.



LEANDER

Rope

Our ropes are made of 100 percent multifilament polypropylene yarn, which makes them particularly light, tear-resistant, and long-lasting. In addition, they are odorless, pliant, and have an elegant silky sheen. Their braiding produces a dimensionally stable round surface. Magnetic sleeves allow them to be quickly and easily attached to the stand and secured by the end caps. To meet your personal requirements, choose from a wide range of colors and select the length you need.

Colors: ■ Black ■ Silver grey ■ Gold ■ Bordeaux ■ Yellow ■ Red
Lengths: 2/2.5/3 m



LEANDER

Rod

For a more understated design, a rod option can be selected as an alternative to the rope. The entire element is made of powder-coated steel, making it particularly robust and durable. No tools are required for assembly. Simply position the magnetic end sleeves in the recess provided on the stand and push down the end cap to lock them in place. The rod is available in two different lengths and in the colors Black or White. Custom lengths and other colors can be produced on request.

Colors: ■ Black □ White | **Lengths:** 1/1.5 m



**Bitte
Abstand
halten**
Please
maintain
distance

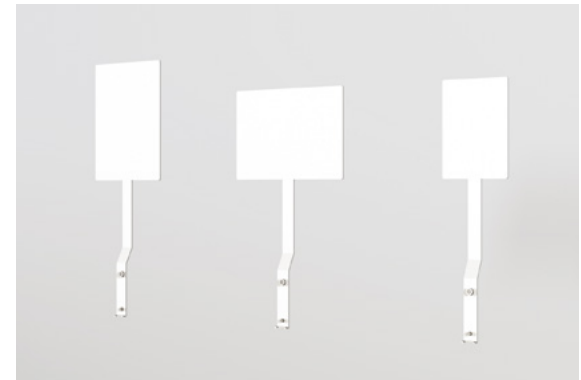

LEANDER

Graphic Element, GSS Series

The GSS series graphic element stands upright and is only slightly angled. This ensures optimal legibility even from relatively far away. The A5 portrait format is ideal for presenting brief information and announcements. With the A4 portrait or landscape format, you have enough space for longer text too. The entire element consisting of sign and holder is made of steel, making it particularly robust and durable. Its powder-coated surface endows it with an elegant and timeless appearance. In addition to the versions in Black and White, other colors are available as customized options.

Colors: ■ Black □ White | **Signage surface:** A4 portrait/landscape, A5 portrait

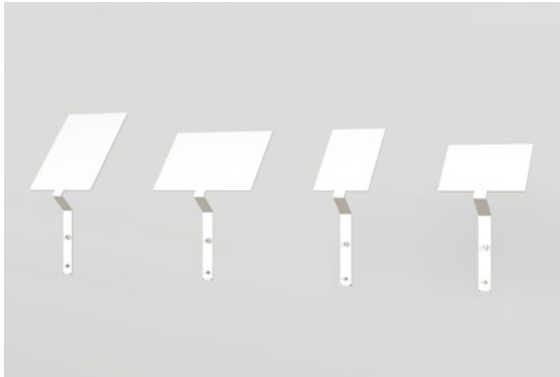

LEANDER

Graphic Element, GSK Series

The GSK series graphic element stands upright but is more angled than the GSS series. The sign is inclined 50°, ensuring good legibility from a relatively short distance. It is available in sizes A4 and A5, and also in both portrait and landscape. The sign and the holder are made of aluminum, with a powder-coated surface for an elegant and timeless appearance. In addition to the standard versions in Black and White, other colors are available as customized options. Graphic films can be applied to the sign surface itself.

Colors: ■ Black □ White | **Signage surface:** A4 portrait/landscape, A5 portrait/landscape



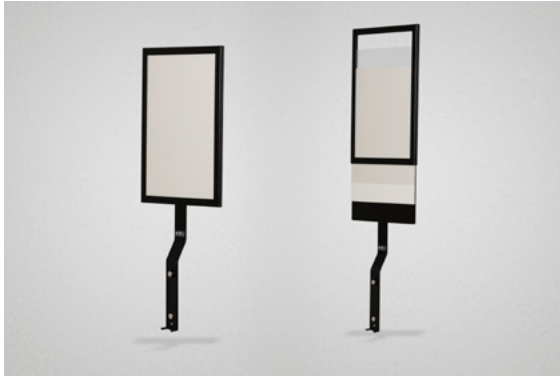

LEANDER

Interchangeable Frame WR

The WR interchangeable frame turns the graphic elements of the GSS and GSK series into upright or angled information units with interchangeable content. The frame slides quickly and easily over the sign surface on those elements. The accompanying acrylic pane provides protection against moisture and other external influences. The interchangeable frame is designed for A4 portrait format, because that format allows optimal display even of detailed text. The entire element is made from aluminum, with a powder-coated surface for an elegant and timeless appearance. Like the whole series, the clip-on frame is available in Black or White. In addition, other RAL Classic colors can be produced as customized options.

Colors: ■ Black □ White | **Signage surface:** A4 portrait

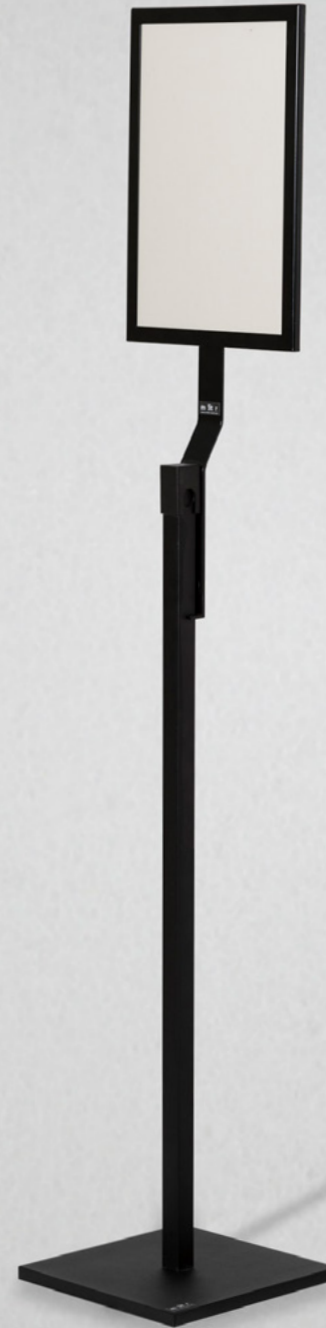



LEANDER

Graphic Element, GGK Series

The GGK add-on element is double-angled so it does not obstruct the observer's view of objects behind it. The 15° inclination of the sign means it can be read in a comfortable posture, and is very suitable for the addition of tactile elements such as Braille or raised black lettering. The display surfaces are available in A5 and A4 landscape formats, and like the holder, are made of steel. This makes them particularly robust and durable. Its powder-coated surface endows it with an elegant and timeless appearance. This element, too, comes standard in Black and White. Other colors can be produced as customized options.

Colors: ■ Black □ White | **Signage surface:** A4/A5 landscape

LEANDER

Holder for Liquid Containers HFB

This holder for liquid containers consists of a multi-folded sheet metal bar, which forms both the support surface and the ring holder. Because of this special design, HFB combines particularly well with the GSS series. The entire element is made of steel, with a powder-coated surface. It comes standard in Black and White, while other colors can be produced as customized options.

Colors: ■ Black □ White



LEANDER

Pump Dispenser Bottle with Sanitizer

5-liter
refill bottle
available

For the element HFB, we also supply a matching pump dispenser bottle with hand sanitizer. The plastic pump dispenser holds 600 ml of the skin sanitizer. It was produced especially for molitor by Preussische Spirituosen Manufaktur according to a WHO formula. The ingredients are 80 percent ethanol (v/v) (MEK), purified water, and 0.1 percent (v/v) hydrogen peroxide. Applied undiluted to the skin, it should be active for two minutes.

Liquid container: 600 ml



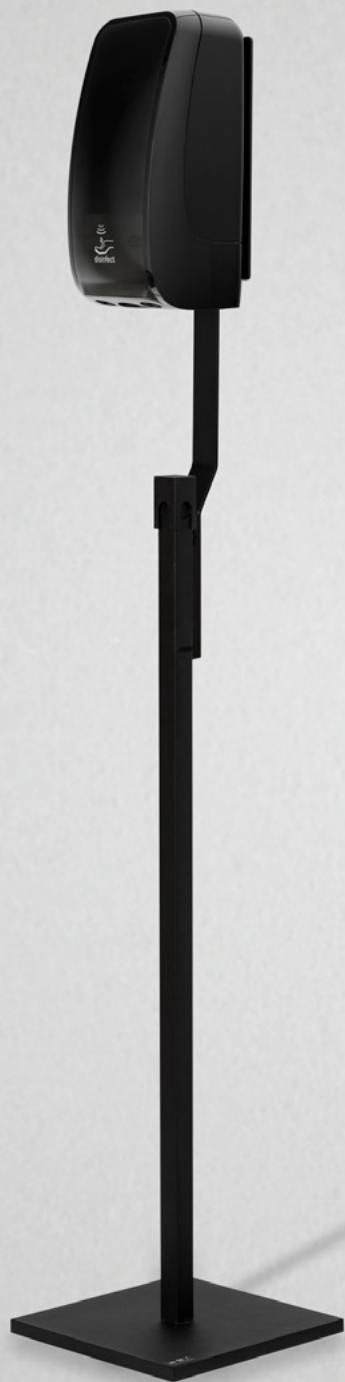

LEANDER

Sanitizer Dispenser with Sensor

For highly frequented areas, the sanitizer dispenser with sensor is an ideal addition to our barrier and guidance system. It can be operated without contact and is therefore particularly hygienic, safe, and innovative. With its small dimensions and compact construction, it conforms to the slim and discreet lines of the LEANDER system. Its cartridge, which can be ordered separately, has a very generous capacity of one liter. The steel stand provides the necessary stability, but the entire element can still be moved easily. It is powered by conventional batteries, so it can operate independently of any external power source.

Colors: ■ Black □ White | **Dimensions:** 25 × 10.5 × 12 cm (H × W × D) |

Cartridge: not included in delivery

1000 ml Hand Sanitizer Cartridge

We supply 1000 ml cartridges of hand sanitizer for our sanitizer dispenser with sensor. With three different dosage settings, it has a very generous capacity and will last for up to 1000 applications. Changing the cartridge is simple and can be done in seconds. The pre-installed pump is always replaced together with the cartridge, which prevents contamination and germ exposure. Every 100 g contains 45 g of 1-propanol and 30 g of ethanol.

Cartridge: 1000 ml



LEANDER

Graphic Element, GSP / QR Code

The GSP graphic element stands upright and is designed to display pictograms or QR codes. The small square sign is inclined 15° to make it easy to hold a phone over it for scanning. The code is applied by means of an adhesive graphic film. As with the entire LEANDER family, the element is made of steel and is therefore particularly robust and durable. Its powder-coated surface endows it with an elegant and timeless appearance. It comes standard in Black and White, and other RAL Classic colors can be produced as customized options.

Colors: ■ Black □ White | **Signage Surface:** 6×6 cm



BARRIER AND GUIDANCE SYSTEM LEANDER



LEANDER

Flyer Holder PSK

The PSK flyer holder is similar in design to the GSK series, but an additional fold gives it a ledge for holding flyers and brochures. With this and its A4 portrait format, even relatively thick documents can be placed on the support surface with no need for additional securing. It is also possible to apply a graphic film to the surface. The shelf surface is inclined 15° for optimal readability. The entire element is made of aluminum and is powder-coated. The PSK comes standard in Black and White, and other colors can be produced as customized options.

Colors: ■ Black □ White | **Tray surface:** A4 portrait

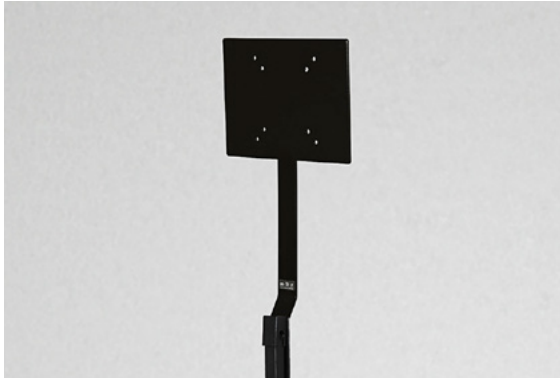

LEANDER

Monitor Holder MSK

Like the SSS series, the MSK monitor holder stands upright and is only slightly angled. This ensures optimal viewing even from relatively far away. The sign has a VESA-standard hole for the mounting of conventional monitors. The entire element is made of steel and is therefore particularly robust, durable, and stable enough to secure even quite large monitors. Its powder-coated surface endows it with an elegant and timeless appearance. The monitor holder comes standard in Black and White, while other RAL Classic colors can be produced as customized options.

Colors: ■ Black □ White

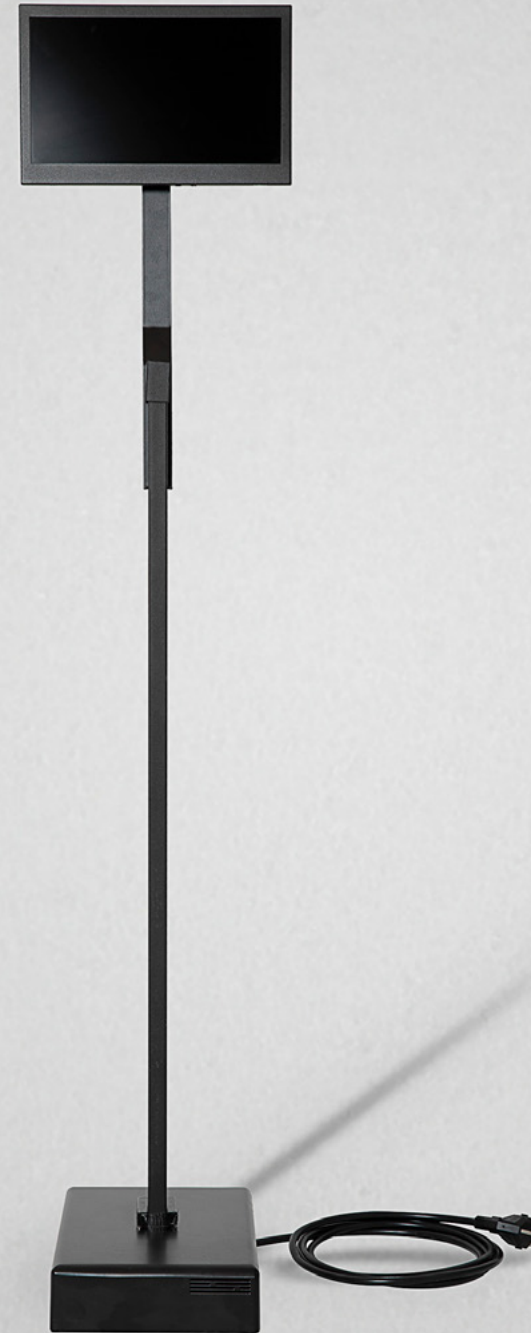

GALLERY —
EXAMPLE INSTALLATIONS



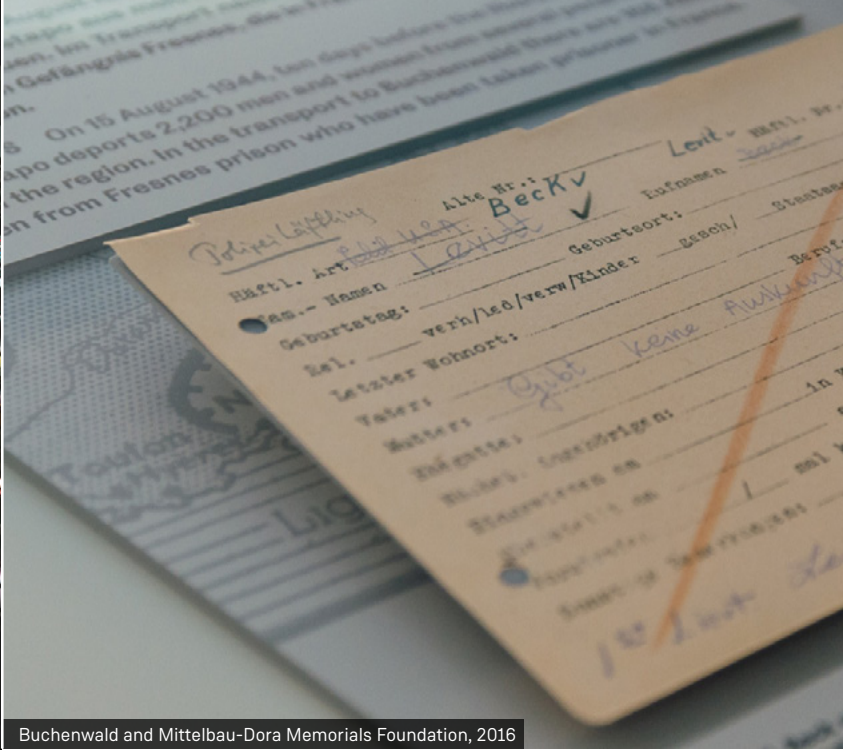

DISPLAY EQUIPMENT

INSPIRED BY OUR WORK

Museum exhibits and their stories are diverse, and so too are the requirements for their display. In principle, the exhibited object should be in the foreground and the mounting should withdraw into the background as much as possible. Restoration conditions must be complied with and structural constraints must be taken into account.

With more than twenty years of experience in exhibit mounting molitor has managed the

display of many different types of objects in numerous exhibitions or designed and planned their presentation.

This experience has resulted in display equipment that can be used for a large number of different exhibits. Some can be simply adapted, while others we design according to specific requirements.

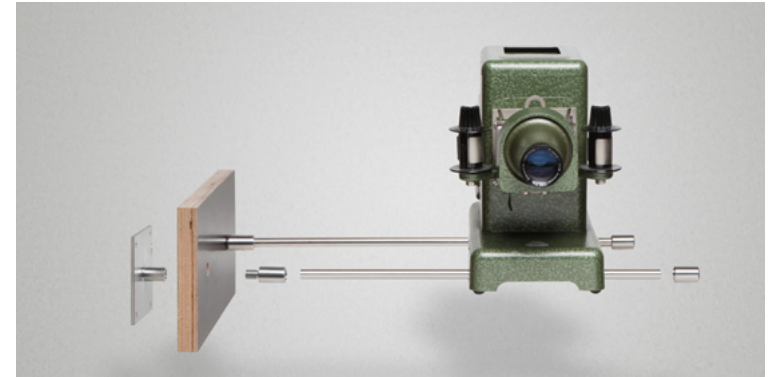
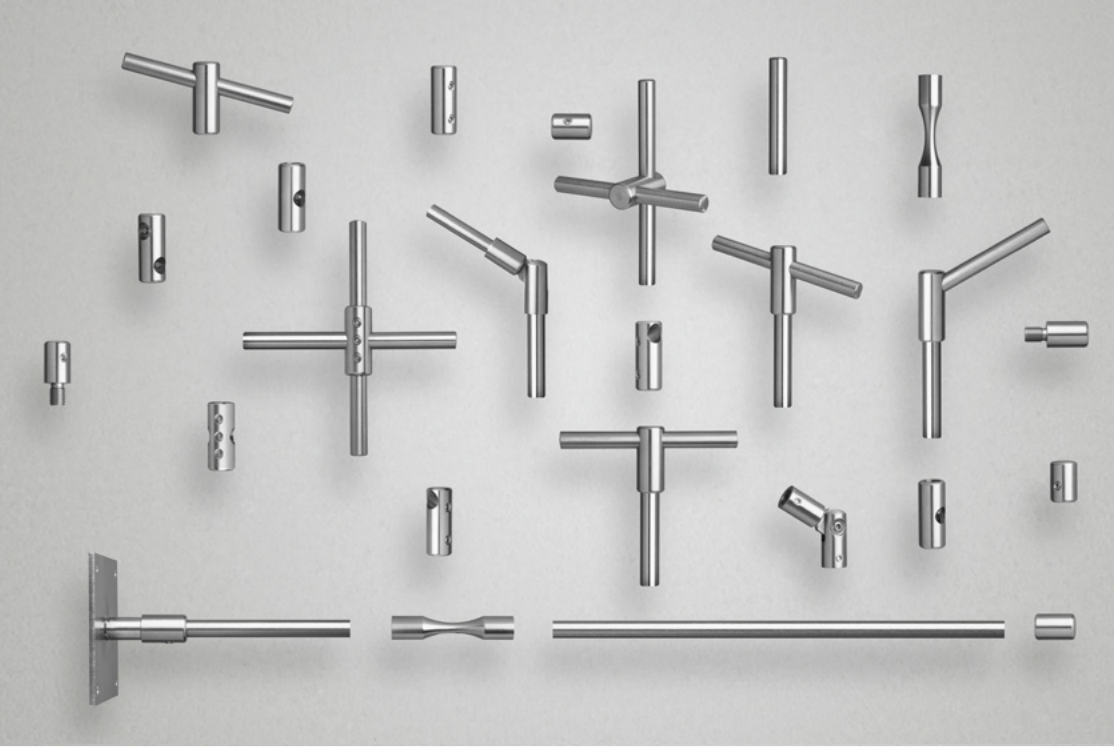

EXHIBIT FITTINGS

Modular Mounting System for Exhibits

This mounting system was designed for securing objects safely to the surfaces of walls and floors. It is also suitable for mounting signage or tactile elements.

The base element is a steel plate with a receptacle sleeve welded onto it. An adapter is screwed into this sleeve which holds a solid rod with a diameter of ten millimeters. Angle and cross elements can be used to create a complex branching design. As a result, shelves, hooks, ring mounts, and spider mounts become secure supports for your exhibits.

The steel plate itself can be fastened behind back panels and under bases in display cases or even on furniture, so that the receptacle sleeve sits flush with the furniture surface. The elements are then fixed in place with setscrews. This allows the system to be adjusted, undone, and reconfigured at any time without wear. All individual parts are made of stainless steel.

Material: stainless steel

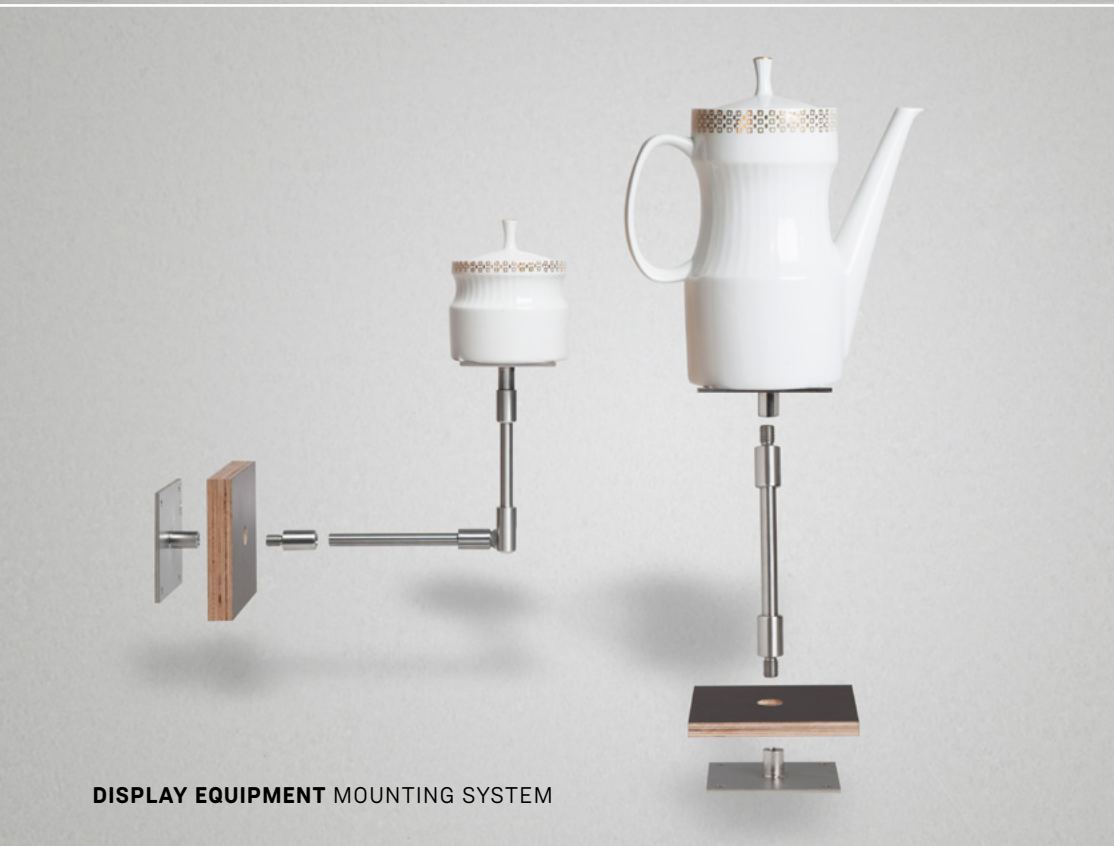

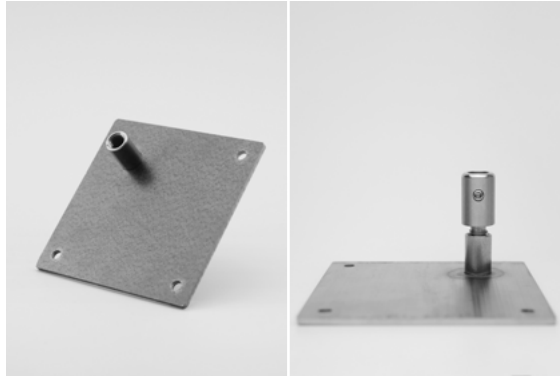

BASE PLATE GP

The base plate provides a stable and securely anchored foundation for the exhibit mounting system. It is usually screwed to the back of the load-bearing surface (e.g. back panel or bottom of a display case). The threaded sleeve is inserted through a hole in the material. The only component visible from the front is the receptacle for the rods, which is screwed into the sleeve. The sleeve is fitted off-center on the base plate to allow maximum use of the edges and corners of the display case.

Base plate dimensions: 100 mm × 100 mm | **Height of threaded sleeve:** 19 mm | **Thread:** M10 | **Combines with:** receptacle



SMALL BASE PLATE GPK

The base plate provides a stable and securely anchored foundation for the exhibit mounting system. It is usually screwed to the back of the load-bearing surface (e.g. back panel or bottom of a display case). The threaded sleeve is inserted through a hole in the material. The only component visible from the front is the receptacle for the rods, which is screwed into the sleeve. This version of the base plate is designed for smaller and lighter constructions.

Base plate dimensions: 40 mm × 20 mm | **Height of threaded sleeve:** 10 mm | **Thread:** M10 | **Combines with:** receptacle



RECEPTACLE TAP

A receptacle for rods 10 mm in diameter, to be screwed into base plates. The rod is fixed in place with a setscrew.

Thread: M10 | **Combines with:** rod, base plate

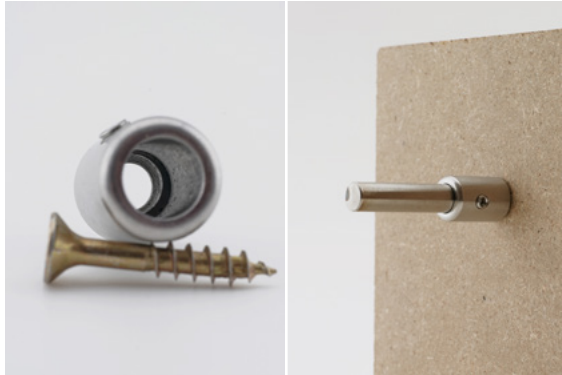

WALL RECEPTACLE **TAP-W**

This receptacle for rods is suitable for use on surfaces that do not allow the installation of components behind them. The component is mounted on the front of the surface with matching screws and, if necessary, plugs. The rod is fixed in place with a setscrew.

Combines with: rod



ROD **RR**

These solid stainless steel rods are available in a variety of lengths and have a diameter of 10 mm. They serve as a basic structural element in the modular exhibit mounting system, and can be joined to each other as desired using various connectors. This allows you to create the ideal customized mounting form for each exhibit.

Dia.: 10 mm | **Length:** 55 mm, 105 mm, 160 mm, 235 mm, 260 mm, 700 mm, 1000 mm | **Combines with:** various

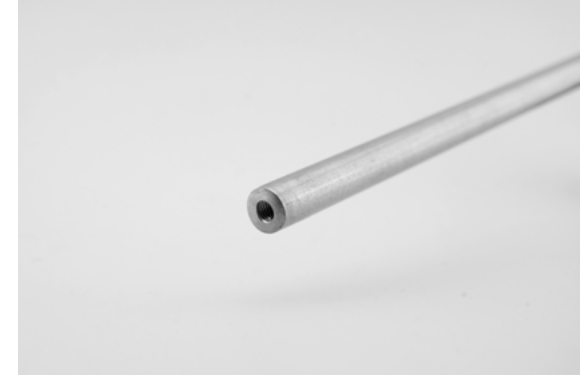

THREADED ROD **RG**

These rods of 10 mm diameter have an internal thread for direct insertion of exhibit mounting components such as hooks, binding plates, rings, sheet mounts, and spider mounts.

Dia.: 10 mm | **Thread:** M5 | **Length:** 600 mm as stock item, other lengths on request | **Combines with:** sheet mount, spider mount, binding plate, ring, hook

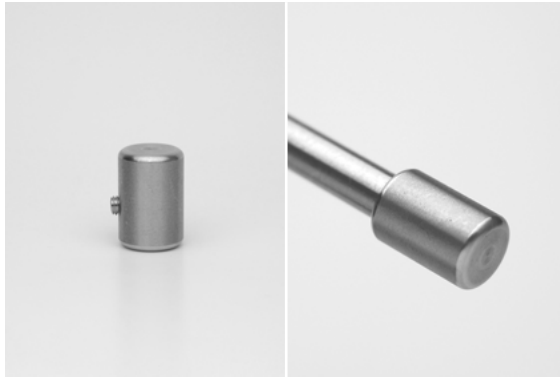

END FITTING

EP

The end fitting provides a neat and elegant termination to a rod while also preventing the artifact from slipping off. The cap is fixed in place with a setscrew.

Combines with: rod



END SLEEVE WITH INTERNAL THREAD

EH

This sleeve with internal thread is fixed to the end of a single rod using a setscrew, to enable further components to then be attached or detached as required. Exhibit supports such as sheet mounts and spider mounts, binding plates, rings, and hooks can be screwed in place on it.

Combines with: rod, sheet mount, spider mount, binding plate, ring, hook



CONNECTOR

C

This component is used for straight-line connection or extension of rods. The rods are fixed in place with setscrews.

Combines with: rods



HOOK
HP

The hook is a load-bearing and open support that prevents the artifact from slipping off. It can also be used to hang artifacts, display panels, and signs. The hook can be screwed easily into the threaded rod.

Thread: M5 | **Combines with:** threaded rod

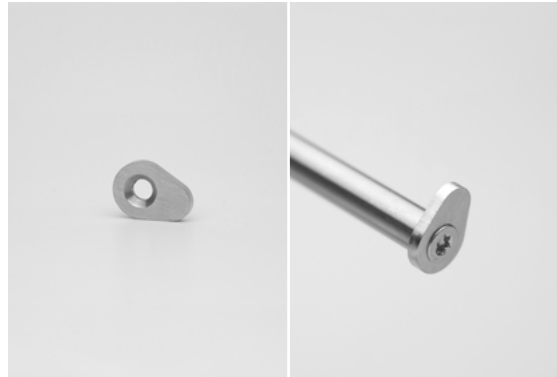

HOOK WITH NOSE
SHN

The hook is a load-bearing and open support that prevents the artifact from slipping off. The hook is fastened to the threaded rod using a countersunk screw.

Combines with: threaded rod

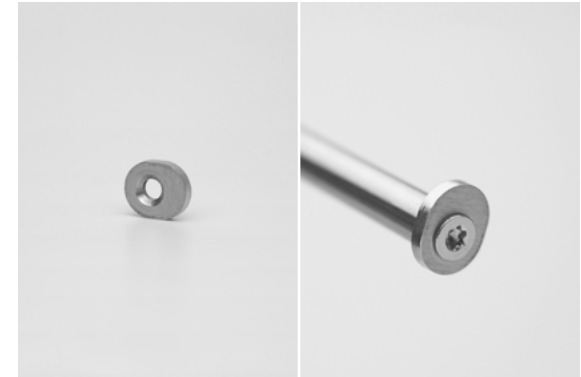

STRAIGHT HOOK
SHG

The hook is a load-bearing and open support that prevents the artifact from slipping off. The hook is fastened to the threaded rod using a countersunk screw.

Combines with: threaded rod



TEE CONNECTOR
TP

The tee connector allows you to connect the end of a rod to another rod at right angles. The rods are fixed in place with setscrews.

Angle: 90° | **Combines with:** rods



DOUBLE CONNECTOR
DC

The double connector allows you to connect a rod to the ends of two other rods at right angles. The rods are fixed in place with setscrews.

Angle: 90° | **Combines with:** rods



CROSS CONNECTOR
CC

The cross connector allows you to connect two rods at right angles with an offset. The rods are fixed in place with setscrews.

Angle: 90° | **Combines with:** rods



75° DOUBLE ANGLE CONNECTOR
APD_75

This double angle connector allows you to connect the end of a rod to another rod at a 75° angle. The rods are fixed in place with setscrews.

Angle: 75° | **Combines with:** rods



60° DOUBLE ANGLE CONNECTOR
APD_60

This double angle connector allows you to connect the end of a rod to another rod at a 60° angle. The rods are fixed in place with setscrews.

Angle: 60° | **Combines with:** rods



45° DOUBLE ANGLE CONNECTOR
APD_45

This double angle connector allows you to connect the end of a rod to another rod at a 45° angle. The rods are fixed in place with setscrews.

Angle: 45° | **Combines with:** rods



75° ANGLE CONNECTOR
AP_75

This connector joins two rods at an angle of 75°. The rods are fixed in place with setscrews.

Angle: 75° | **Combines with:** rods



60° ANGLE CONNECTOR
AP_60

This connector joins two rods at an angle of 60°. The rods are fixed in place with setscrews.

Angle: 60° | **Combines with:** rods



45° ANGLE CONNECTOR
AP_45

This connector joins two rods at an angle of 45°. The rods are fixed in place with setscrews.

Angle: 45° | **Combines with:** rods



ADJUSTABLE ANGLE CONNECTOR

AJ

The angle of this connector can be varied from 0° to 110° on either side, for fine adjustment of the mount to suit the artifact and the display conditions. The variability of the connector also makes it ideal for exhibit mounting systems intended for repeated use. The rods are fixed in place with setscrews.

Angle: variable, -110° to 110° | **Combines with:** rods

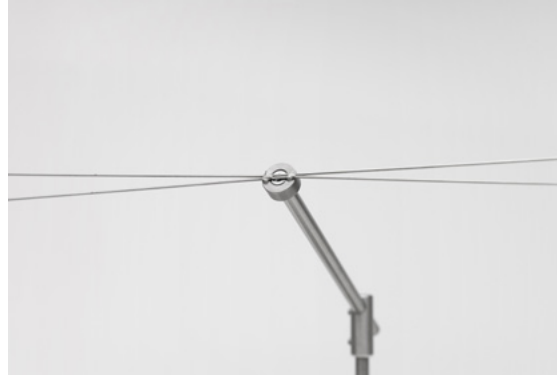

SPIDER MOUNT

KH

The legs of the spider mount can be bent or shortened as required, and thus adapted in any way to suit the artifact. The spider mount is fixed in place on the end of a rod with a setscrew. Suitable not only for artifacts that are symmetrical in shape, but also and especially for those that are asymmetrical.

Length of the legs: 200 mm | **Combines with:** rod



SHEET MOUNT

SM

Component for attaching light two-dimensional artifacts such as bound sheets. For stability in both directions, sheet mounts can also be used in a cross-wise arrangement. In addition, the pliable material allows you to bend the sheet mounts as desired to create various other mounting forms. The sheet mounts have a hole in the center for direct fastening to the threaded rod.

Sizes: 100 × 12 mm, 150 × 12 mm, 200 × 12 mm, 200 × 15 mm, 250 × 15 mm, 200 × 20 mm, 250 × 20 mm | **Material thickness:** 0.5 mm | **Combines with:** threaded rod



LARGE BINDING PLATE

SAG

Large artifacts that are more or less rectangular can be positioned on this mounting surface. The plate is installed with a countersunk screw inserted into the internal thread of the rod.

Size: 70 × 100 mm | **Combines with:** threaded rod

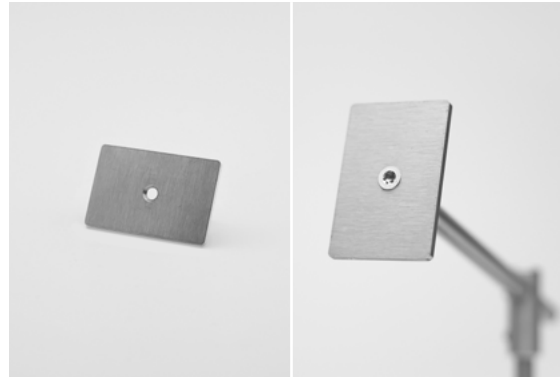

SMALL BINDING PLATE

SAK

Small artifacts that are more or less rectangular can be positioned on this mounting surface. The plate is installed with a countersunk screw inserted into the internal thread of the rod.

Size: 40 × 60 mm | **Combines with:** threaded rod

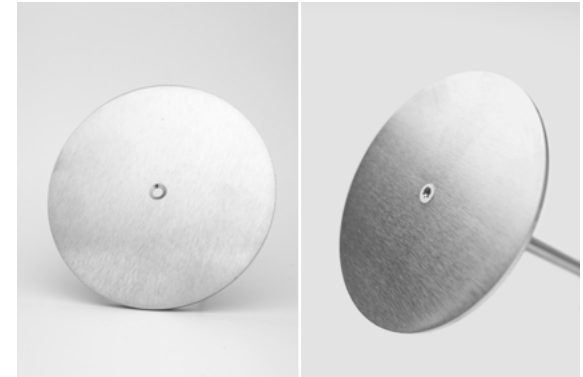

ROUND BINDING PLATE

SAR

Large circular artifacts can be positioned on this round binding plate. The plate is installed with a countersunk screw inserted into the internal thread of the rod.

Dia.: 120 mm | **Combines with:** threaded rod

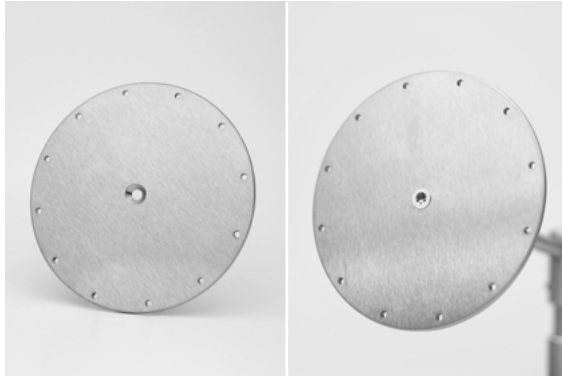

ROUND BINDING PLATE WITH HOLES **SARg**

Large circular artifacts can be displayed on this round binding plate. The holes allow the artifact to be securely fastened on the mount. The plate is installed with a countersunk screw inserted into the internal thread of the rod.

Dia.: 120 mm | **Combines with:** threaded rod



LARGE RING **SRG**

This ring is used to display large circular or spherical artifacts. The holes allow the artifact to be securely fastened on the mount. The plate is installed with a countersunk screw inserted into the internal thread of the rod.

Dia.: 140 mm | **Combines with:** threaded rod

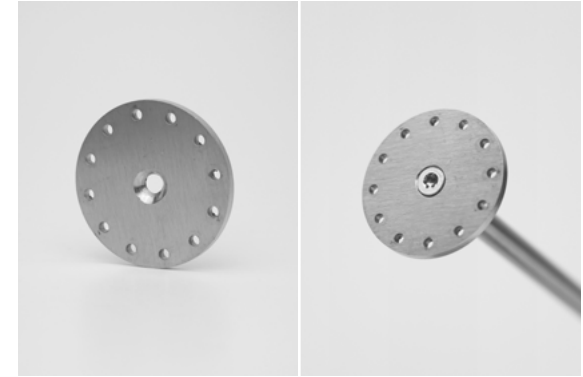

SMALL RING **SRK**

This binding ring is used to display small circular or spherical artifacts. The holes allow the artifact to be securely fastened on the mount. The plate is installed with a countersunk screw inserted into the internal thread of the rod.

Dia.: 40 mm | **Combines with:** threaded rod

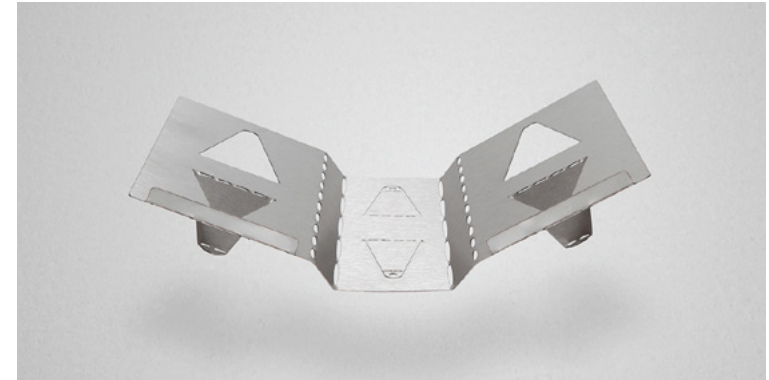

EXHIBIT FITTINGS

Book Cradle

Book cradles are particularly well suited for presenting valuable books and other bound works in a protective and appropriate manner. They consist of a rigid part and an adjustable part that can be adapted to suit the specific object displayed. The primary concern of every book cradle is to protect the sensitive bindings.

Our book cradle is made of simple laser-cut sheet metal. It can be easily arranged into the desired position, and the angle of inclination can be optimally adjusted to the book. The lip on the bottom edge makes it possible to stand the book almost completely upright. The flexible mount of the cradle is suitable for mounting on walls, as well as on horizontal display panels.

The size of the book cradle can be adjusted to the dimensions of the artifact. A painted stainless steel cradle is also available. For safe use of the cradle, we recommend using an acid-free museum mounting board as an intermediate layer.

Material: stainless steel | **Size:** customizable



EXHIBIT FITTINGS

Sheet Display Board

Unbound artifacts such as drawings, lithographs, and prints are presented hanging or lying flat. For optimal viewing, the angle of inclination of the artifact is crucial for both options.

molitor's sheet display board combines both types of display, and can be individually adjusted. Made from simple laser-cut sheet metal, it can be easily bent into the desired position on its integrated supports. The angle of inclination is thus optimally adapted to the sheet and the viewer. The flexible mount makes the board suitable for mounting on walls, as well as on horizontal display panels.

The sheet display board comes in A4 and A5 sizes and in portrait and landscape formats. The stainless steel can also be delivered painted upon request. For safe use of the board, we recommend using an acid-free museum mounting board as an intermediate layer.

Material: stainless steel | **Size:** A4/A5 portrait/landscape



EXHIBIT FITTINGS

Spider Mount

Aesthetic and appropriate display of museum exhibits is a basic requirement for achieving the best possible effect.

To do justice to the many different facets of exhibits, molitor has developed a system that retreats behind the object. The form-fitting system holds the artifacts in place, whether they are aligned vertically or horizontally. The stainless steel wires covered with silicone tubing are bent around the object and trimmed as required. Like small claws, they then hold it securely without exerting pressure. This ensures damage-free display. The combination of standardized production and individual adaptability is also an impressively cost-effective and simple solution.

Material: stainless steel and silicone

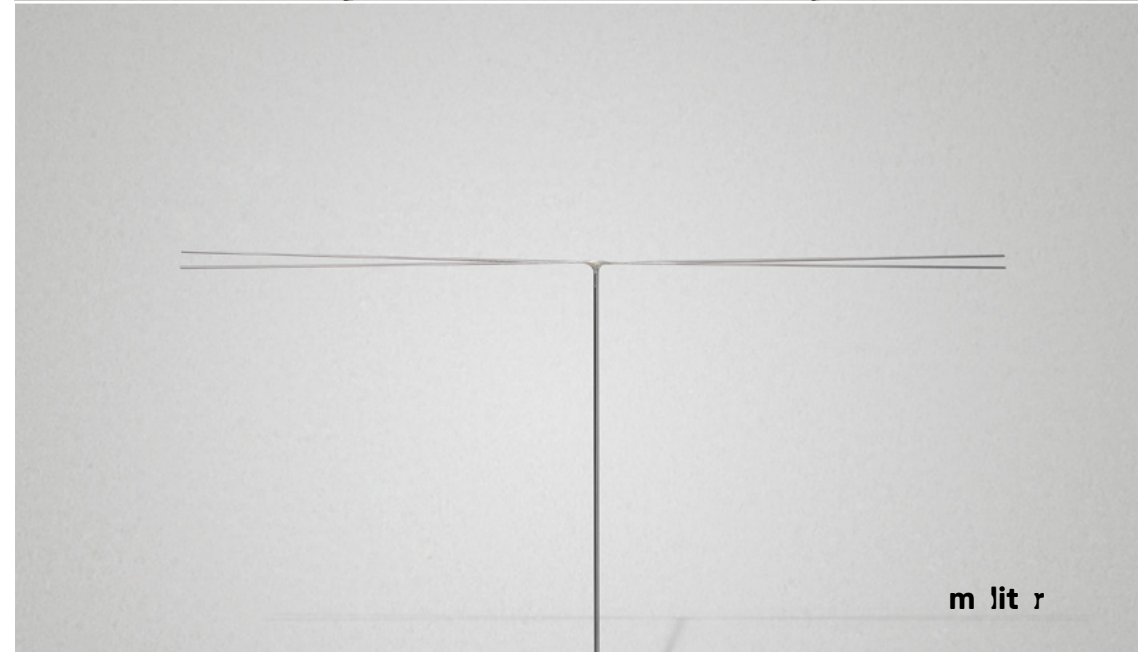



"Diversity Destroyed" theme year, Berlin 2013

COLUMNS

EXCELLENT VISIBILITY ALL ROUND

About 170 years ago, the Berliner Ernst Litfass recognized the potential of the column as an information medium, and set his own standard with the "Litfass column" named after him.

Taking our lead from him, we chose a format for our columns that ensures a good balance between public visibility, usable surface area, and logistical cost. It is especially well suited to temporary installations.

The columns are made of fiberboard and are laminated with plastic film. The signage content is applied by 4C printing on scratch-resistant and light-fast film, which provides additional protection. The necessary wind stability is provided by the levelable base which is loaded with weights. A thermo-formed plastic lid securely covers the top of the column. As a full service provider, we can perform all steps from graphic design to installing and removing the columns.



Stadt-Land gestalten, Oderbruch/Letschin 2016, height: 2.3 m



European Mobility Week, Friedrichstrasse, Berlin 2020, height: 2.2 m

COLUMNS

Outdoors

For outdoor use, our columns are designed with numerous details that make them resilient and durable for long periods of time. A roof made of plastic plus protective features in the floor make these easy-to-transport information carriers the ideal display equipment for the outdoors. Thanks to their impressive height of up to 4 meters, they are clearly visible even from a distance. As a result of creating so many of them over the years, our columns are now predominantly manufactured from standardized components. Consequently we can produce them faster and at lower cost. We provide everything you need, from graphic design through to lamination and to installation on site.

Material: fiberboard laminated with plastic film | **Diameter:** 1 m | **Height:** up to 4 m



Diversity Destroyed, Charite hospital, Berlin 2016, height: 4 m



Berlin's 775th Anniversary, special construction with straight connecting pieces, Berlin 20



C/O Berlin, B-Part Am Gleisdreieck 2020, height: 3 m



Zauche, Ziegel, Zisterzienser, Kloster Lehnin 2017, height: 2.3 m

DISPLAY SYSTEMS COLUMNS



COLUMNS

With Embedded Media

Sturdy columns made of fiberboard are ideally suited to accommodate technical add-ons due to their large volume. This means you can integrate monitors, loudspeakers, and headphones into them. Decorative attachments can also be added, just as easily as the inlays that hold media equipment. Supplementary lamps put the column in the right light. In addition to producing the columns, we are also happy to provide you with media and lighting systems.



"Former Inner German Border" educational facility, Neustadt bei Coburg 2019

INFORMATION BOARDS

MULTIFUNCTIONAL COMMUNICATORS

Information boards are versatile information carriers – they can be made in numerous shapes, colors, and sizes and can be equipped with a very wide range of media. In addition to images and text, you can integrate screens, artifacts, and slide viewers to enrich the overall design and content. Information boards give you a lot of surface area on a minimal footprint. This lets you position content as you like, and have it clearly visible from any direction.

So the information boards can be used outdoors for long periods, we use steel or aluminum sheets that are thoroughly protected against corrosion by several protective layers. We use a special powder coating process to seal printed areas so they are durable and vandal-proof. The required stability is provided by base plates, or foundations that firmly anchor the columns.



INFORMATION BOARDS

Outdoors

Information boards are ideal for going beyond printed text and images, to further levels of exploration. Monitors, media stations, hands-on features, backlit surfaces, and even display cases can be integrated easily. Sensors can trigger effects, for enhancements with a dimension of surprise. Robust construction in sheet metal with protective surface sealing ensures durability.



INFORMATION BOARDS

Indoors

In indoor areas, information boards can be constructed in a wide variety of materials. Media installations can be integrated, and the options for surface design are virtually unlimited. Information boards can also be used to hold interactive exhibits. The graphical content can be applied using many different techniques. We are happy to draw on our many years of experience to advise you. We also provide everything you need from planning to installation.



Summer of Love, Palais Populaire, Berlin 2019



Long Night of Museums, German Historical Museum, Berlin 2018



Saxon State Exhibition, Torgau 2004

PERIAKTOI

— TRIANGULAR COLUMNS WITH MANY FACETS

In ancient Greek theater, revolving periaktoi were used for rapid scene changes. Our periaktoi, on the other hand, with their different motifs on each side, create surprising changes of perspective in indoor and urban spaces.

In addition to the many possibilities for displaying images and text, the heights and edge lengths can also be customized. To ensure stability regardless of height, the base elements

are fitted with a balancing weight, and are designed to compensate for uneven floors.

Our periaktoi are delivered complete with printed film and balancing weight. We also install the elements directly at the site.

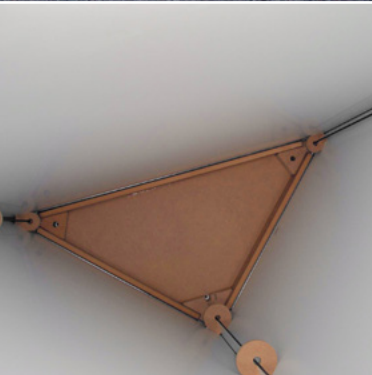
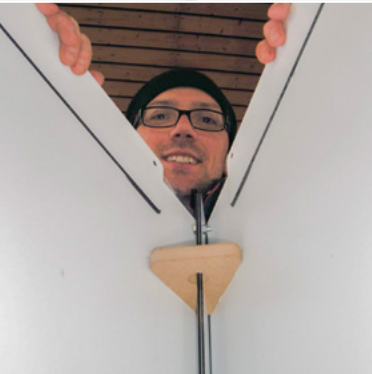

Our standard periaktoi system brings together many attractive features:

- Usable as a single unit, but also to form walls
- Minimal storage volume
- Quick and easy to assemble and disassemble due to standardized, precision-fit components
- Tough and sturdy, for reuse as often as required

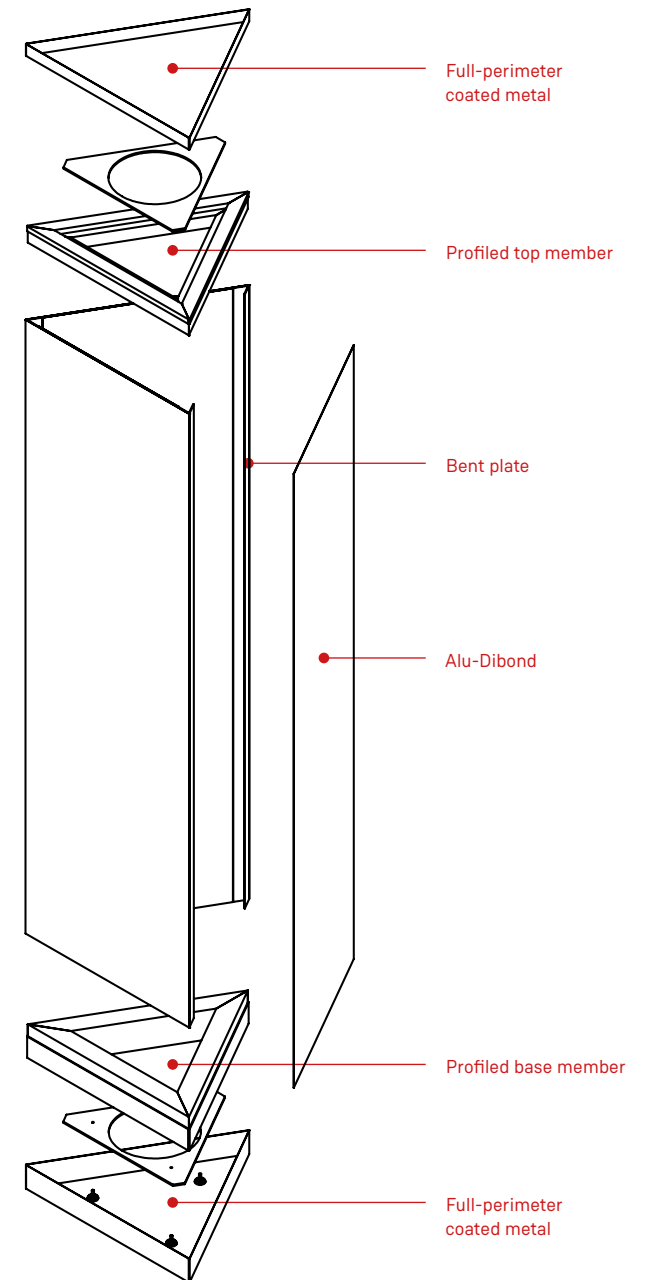
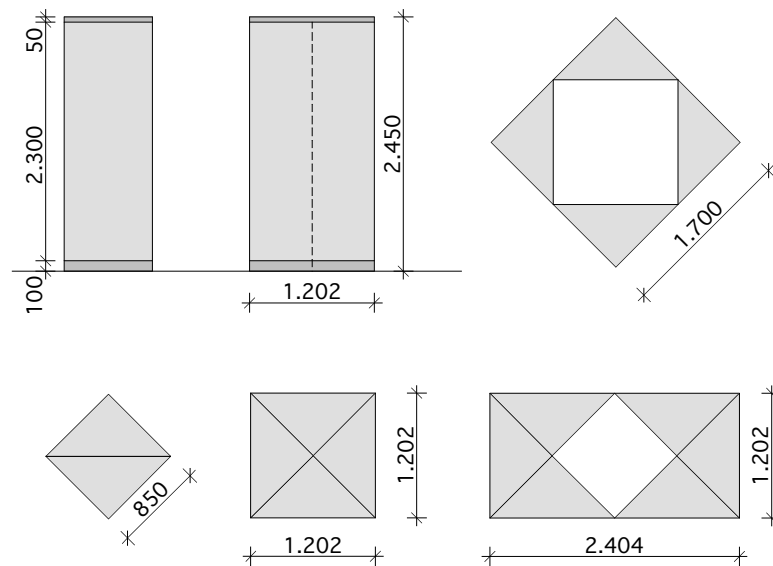



PERIAKTOI

Outdoors

For outdoor use, we manufacture periaktoi from sheet metal or composite materials, which are then covered with 4C-printed film and a protective laminate. The balancing weight comprises a cast concrete base or weights in the structure.

Periaktoi can be stored space-efficiently, and can be easily redesigned by applying new film coverings.



PERIAKTOI

Customized for Indoors

Triangular columns can be useful in indoor spaces as eye-catchers and information carriers. Custom-made periaktoi can incorporate media equipment, display cases, and backlit surfaces. They can be created with a huge variety of materials and surface types. We also design them in such a way that they can be assembled and disassembled repeatedly without difficulty.

LEGAL NOTICE

m l i t r
m.o.l.i.t.o.r. GmbH
Schlesische Str. 31
10997 Berlin

Tel: +49 - 30 - 62 90 19 - 0
Fax: +49 - 30 - 62 90 19 - 19
info@molitor-berlin.de
www.molitor-berlin.de

Geschäftsführer: Martin Müller,
Michael Zeyfang, Marco Unterhaslberger

Managing directors: Martin Müller,
Michael Zeyfang, Marco Unterhaslberger

The texts and photographs in this catalog are protected by copyright. All rights are reserved by m.o.l.i.t.o.r. GmbH or its contractual partners. Any form of publication, transfer to third parties, or commercial use is permitted only with the written consent of m.o.l.i.t.o.r. GmbH.

Translation: Nat Shockley
Product photography: Waldemar Salesski
Some of the product photographs were taken in the museum "Deutsche Kinemathek - Museum für Film und Fernsehen."

Last updated: May 01, 2022